



Sarouel Pants for a Grown-up

Design & Work: Anriko
 Size: about 100cm (hip) 27.5 (rise)
 60cm (inside leg)

Materials

- Fabric (front and back pants, waist belt, pocket) : 110cm wide x 2m
- (Rib knit) (Rib for hem): 30cm x 30cm
- Fusible interfacing: 60cm x 20cm
- Elastic tape: 2cm wide x 70cm

Fabric shown for this sample: echino Huedrawer fragment JG96300-302 (D)

Pattern

All measurements are in centimeters (cm)

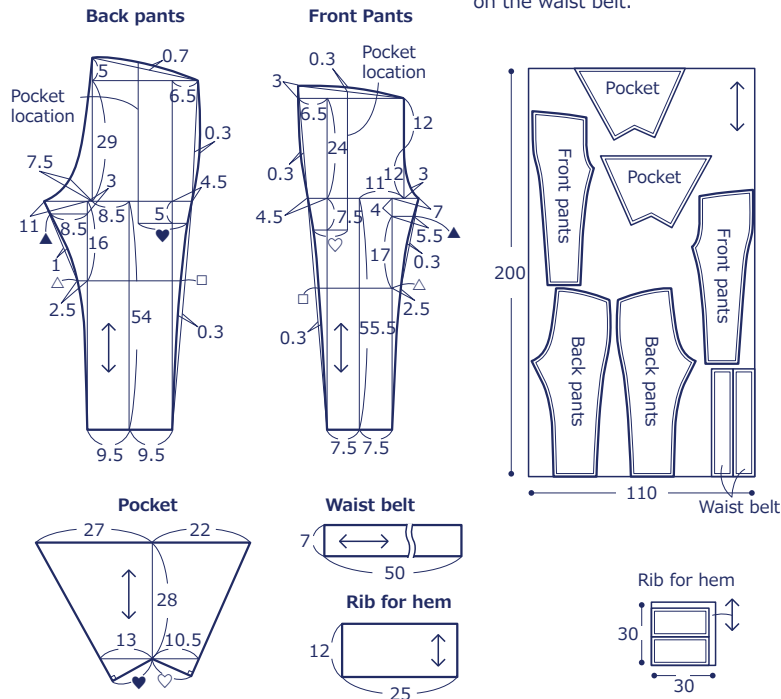

Cutting layout

Add 1cm seam allowance.
 Adhere fusible interfacing on the waist belt.

The craft projects and works featured in kokka-fabric.com are strictly for personal use and enjoyment.
 Please refrain from selling handmade items using the same exact design (including the pieces made in different fabrics) featured in kokka-fabric.com.

Instructions

6. Make the waist belt

① First, fold the seam of the long side. Then fold in half with the front sides facing outside.
 • Make two pieces

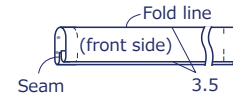

② Open the crease. With the front sides facing each other, sew together the pieces on both ends. (Leave an opening for elastic tape on one side.)

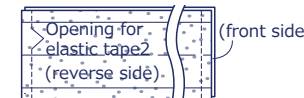

③ As shown, put together the front and back pants and sew together.

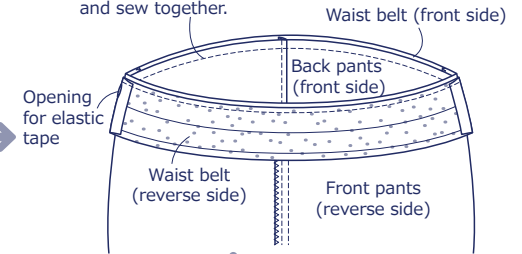

④ Turn the waist belt inside out and fold along the crease line. Run stitches from the front.

1. Sew the crotch

With front sides facing each other, put together front and back pants and sew the crotch. Serge the seam of both front and back together and press down to the left side. Run stitches from the top.

4. Repeat the process as in step 2 and 3 to sew the other side and make a pocket.

5. Sew the inside leg

With front sides facing each other, put together front and back pants and sew the inside leg. Serge the seam of both front and back together and press down to the back.

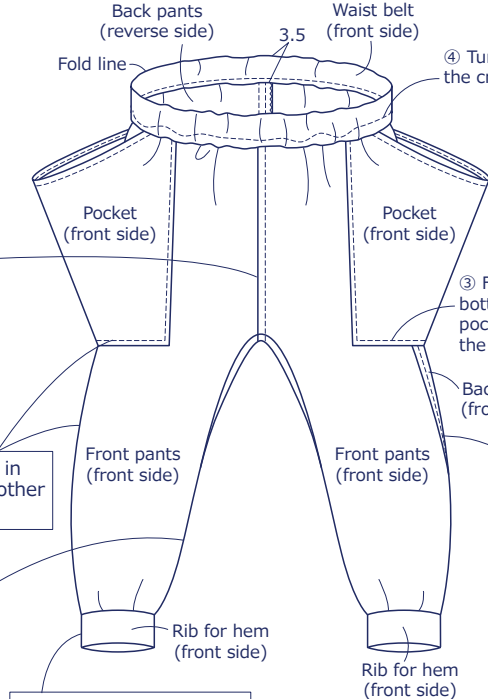

8. Make the rib for hem

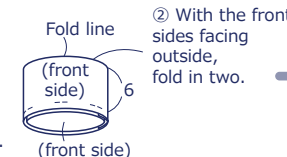
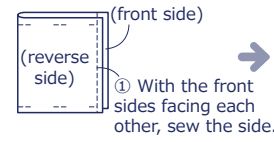

7. Put through the elastic tape

Put through the elastic tape (68cm) and overlap the ends for 2cm and sew to secure.

3. Make the pocket

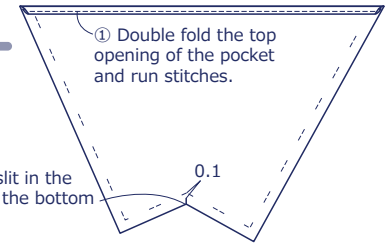

2. Sew one of the sides

With front sides facing each other, put together the front and back pants and sew one of the sides. Serge both seams together, press it down to the back and run stitches.

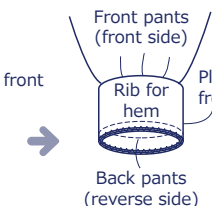

③ As shown, put together the front and back pants and rib for hem and sew together. Serge both seams together.
 • Make two pieces