



Salopette (Overall) Skirt

Design & work: Anriko

Size: Length about 125cm
(including shoulder strap)

have fun with KOKKA fabric! produced by **KOKKA**

kokka-fabric.com

The craft projects and works featured in kokka-fabric.com are strictly for personal use and enjoyment.
Please refrain from selling handmade items using the same exact design (including the pieces made in different fabrics) featured in kokka-fabric.com.

Materials

- Fabric: 110cm wide x 2.1m
- Double fold bias tape: 12.7mm wide x 1.5m
- Elastic tape: 0.4cm wide x 90cm

Fabric shown for this sample: 3min. JGA20060-1D

Pattern

Unit is cm

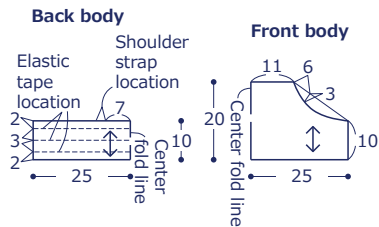

Front and Back Skirt

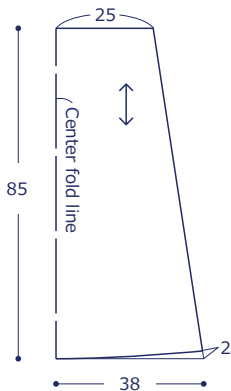

Cutting Layout

Numbers in () denote seam allowances. Add 1cm seam unless otherwise stated.

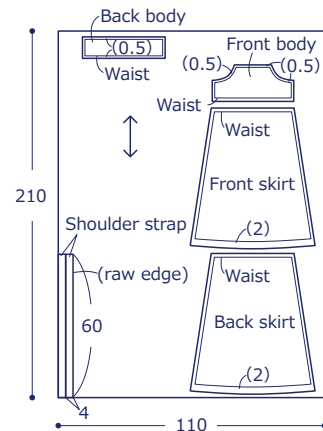

Instructions

- ① With the front sides facing each other, sew together the front and back bodies and skirt at the sides respectively. Apply zigzag stitches on the seam together and press it down to the back side.
- ② With the front sides facing each other, sew together the body and skirt at the waist. As in process ①, finish the seam and press it down to the body side.
- ③ Make the shoulder straps.
- ④ Treat the seam of the armhole and the back body at the top.
- ⑤ Attach the elastic tape.
- ⑥ Treat the seam of the front body at the top.
- ⑦ Double fold the seam of the hem and sew.

Shoulder strap (front side) - Make two pieces.

Bias tape (reverse side) - Turn the bias tape over to the front. Fold both ends and apply stitches.

Place the elastic tape (30cm each) over the back body. Stretch the elastic as you stitch onto the back body.