



# Semi-Fitted Skirt

Design & Work: Yoko Kato

Size: Length M - 86.5cm L - 89.5cm

have fun with KOKKA fabric! produced by KOKKA

[kokka-fabric.com](http://kokka-fabric.com)

The craft projects and works featured in kokka-fabric.com are strictly for personal use and enjoyment. Please refrain from selling handmade items using the same exact design (including the pieces made in different fabrics) featured in kokka-fabric.com.

## Materials

- Fabric: 110cm wide x 1.9m for Medium, 2m for Large
- Elastic Tape: 3cm wide x 66cm for Medium, 70cm for Large

Fabric shown for this sample: EKX-1440-2A

## Pattern

Unit: cm  
Dimensions are the same for both M and L unless otherwise specified.

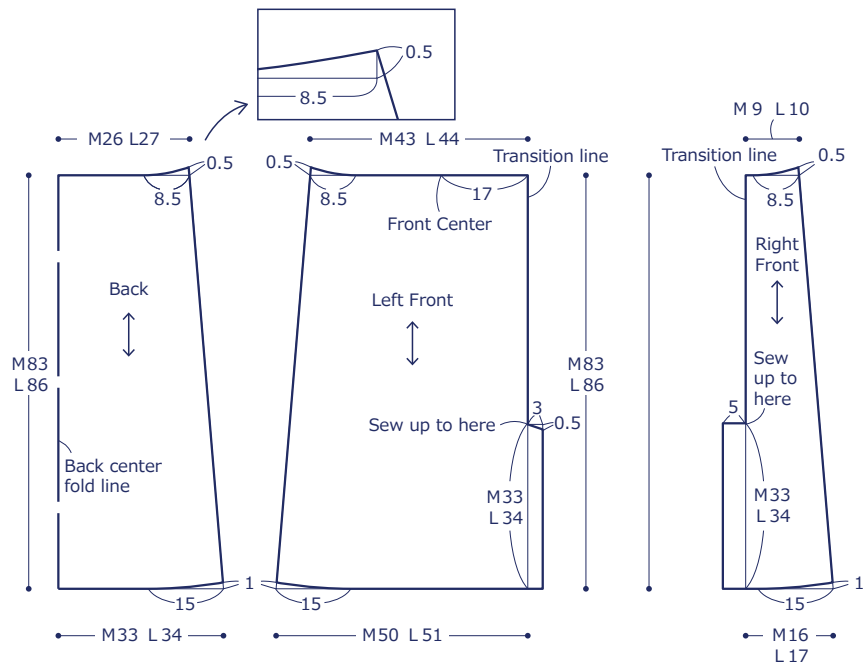

## Cutting Layout

( ) denotes seam allowance Add 1cm seam allowance unless specified otherwise

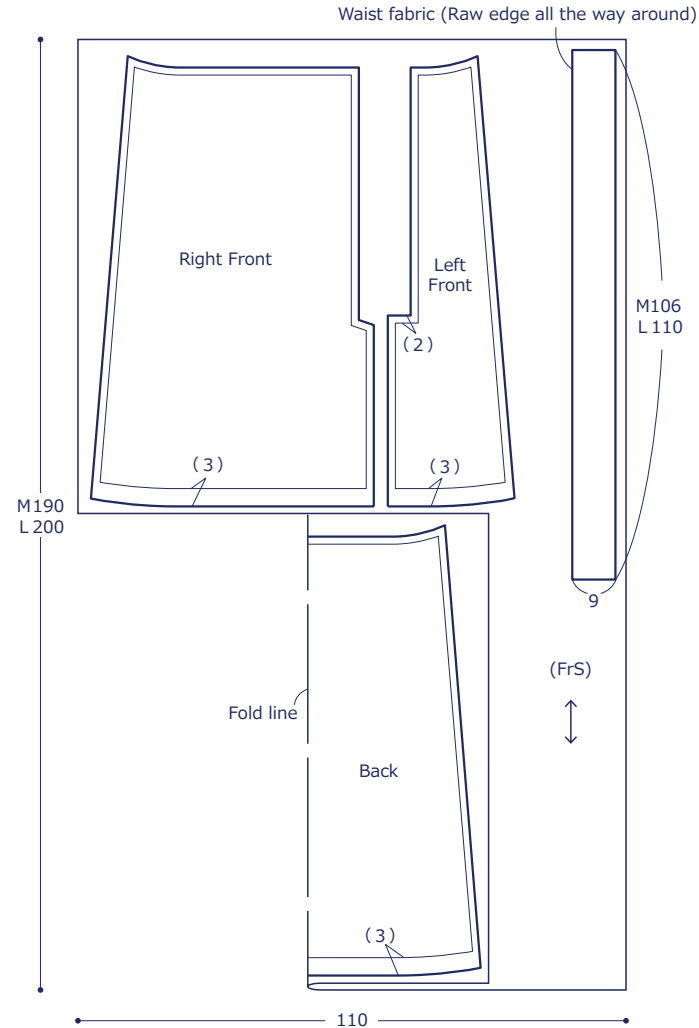

Continued on the second page

The craft projects and works featured in kokka-fabric.com are strictly for personal use and enjoyment. Please refrain from selling handmade items using the same exact design (including the pieces made in different fabrics) featured in kokka-fabric.com.

**Instructions** Front Side - (FrS), Reverse Side (RvS)

4 Make the waist fabric.

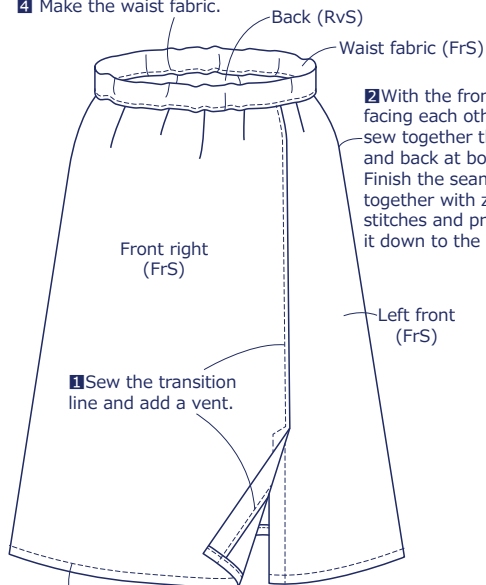

2 With the front sides facing each other, sew together the front and back at both sides. Finish the seams together with zigzag stitches and press it down to the back side.

1 Sew the transition line and add a vent.

1 Apply zigzag stitches on the seam of ①.

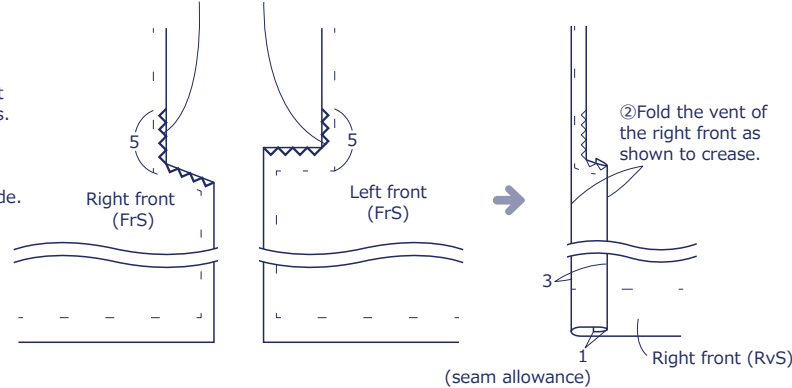

2 Fold the vent of the right front as shown to crease.

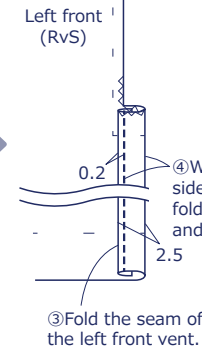

3 Fold the seam of the left front vent.  
4 With the front side facing outside, fold as shown and sew.

4

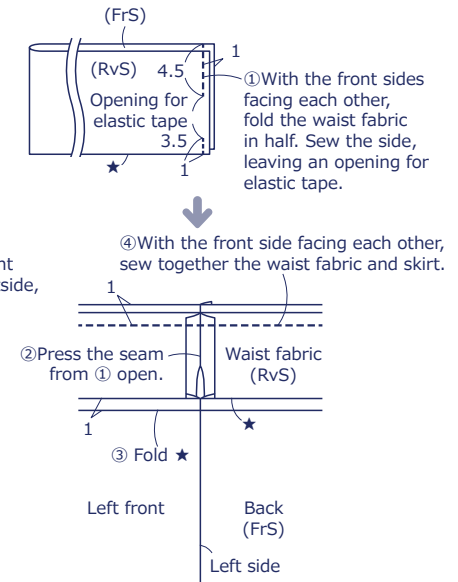

1 With the front sides facing each other, fold the waist fabric in half. Sew the side, leaving an opening for elastic tape.

4 With the front side facing each other, sew together the waist fabric and skirt.

2 Press the seam from ① open.

3 Fold ★

3 Fold the seam of the hem in three and sew.

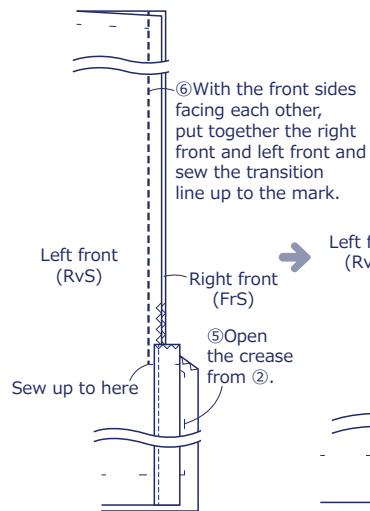
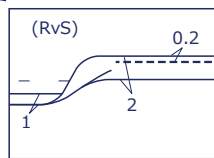

6 With the front sides facing each other, put together the right front and left front and sew the transition line up to the mark.

8 Finish the seam of the transition line together with zigzag stitches and press it down to the right front side.

7 Fold the right front along the fold line from ② and sew. Sew the top portion up to the mark.

9 Apply stitches.

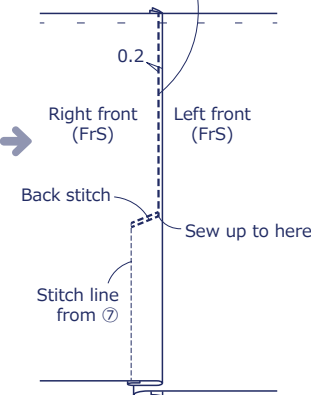

5 With the front sides facing outside, fold the waist fabric in half, wrap the seam and sew.

