



Drink Bottle Holder

Design & work: Satomi Takei

Size: 22.5cm (l)
 14cm (w - opening side) 7cm (bottom)
 7cm (gusset)

Materials

- Fabric (Body): 35cm x 25cm
- Fabric (Opening Fabric, Bottom Fabric): 35cm x 20cm
- Fabric (Tab (Faux Leather)): 2cm x 5cm
- Elastic Tape: 0.7cm wide x 20cm
- Rivet: 0.7cm diameter x One pair

Fabric shown for this sample: YPA-71010-1A

Pattern & Cutting Layout

Unit: cm All raw edge

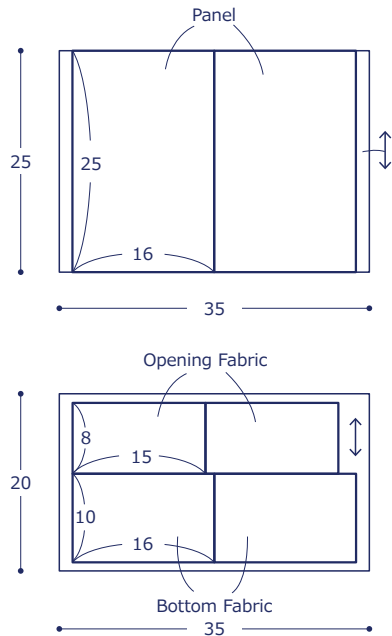

The craft projects and works featured in kokka-fabric.com are strictly for personal use and enjoyment. Please refrain from selling handmade items using the same exact design (including the pieces made in different fabrics) featured in kokka-fabric.com.

Instructions Front Side - (FrS), Reverse Side (RvS)

1. Make the opening fabric and bottom fabric

<Opening Fabric>

Fold both sides and sew.

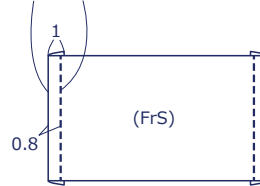

• Make two pieces.

<Bottom Fabric>

Fold the top edge.



• Make two pieces.

2. Make the panel

① With the front sides facing outside, fold the opening fabric in half. With the front sides facing each other, put it together with the panel and sew the opening side.

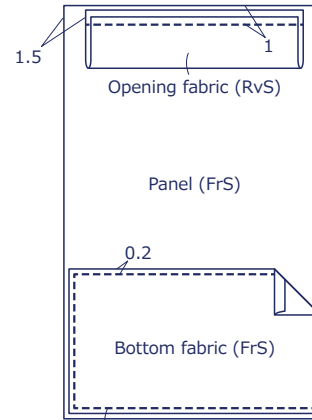

② Attach the bottom fabric to the panel.

④ Pull up the opening fabric and apply stitches.

⑤ Sew the opening for the elastic tape.

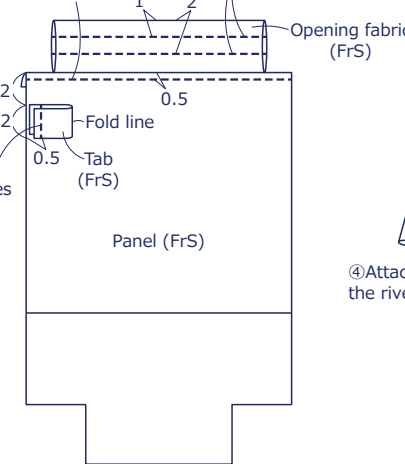

• Make another piece following the same process as in ①~⑤.

3. Finish the holder

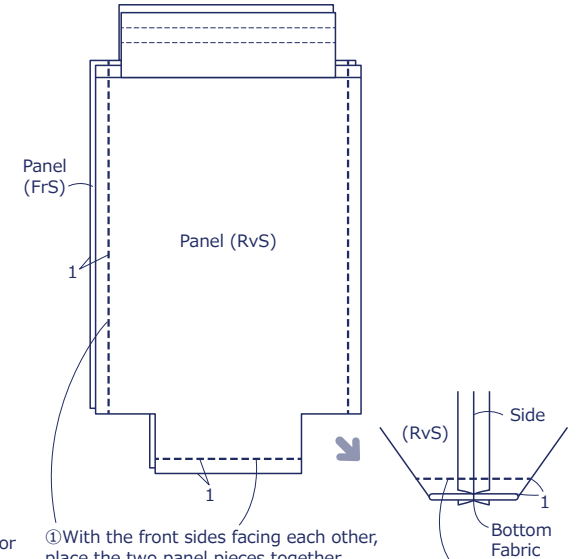

① With the front sides facing each other, place the two panel pieces together and sew the sides and bottom.

② Press the seam open. Sew the gusset by folding both sides of the bottom as shown. • Repeat the process on the other side.

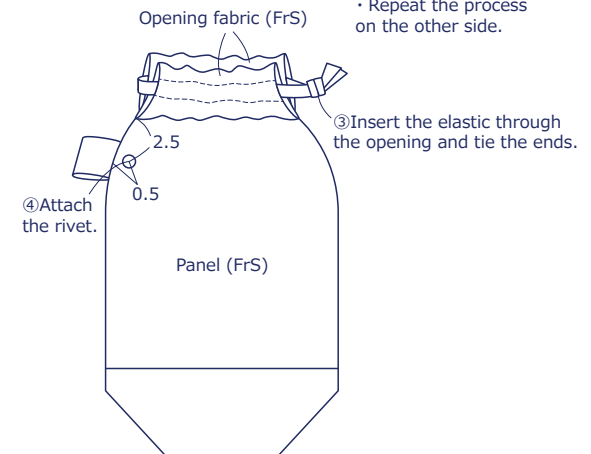

④ Attach the rivet.

③ Insert the elastic through the opening and tie the ends.