



Two-Way Skirt

Design & work created
by Masumi Saito (sinafuku)

Size: Length 33.5cm

have fun with KOKKA fabric! produced by **KOKKA**

kokka-fabric.com

Materials

- Fabric (Top chest portion, Skirt a): 90cm×80cm
(Skirt b): 80cm×50cm
- Elastic Tape (1cm wide): (Waist measurement + 1cm) × Four pieces

Fabric shown for this sample: P31300-300 (E), P31300-301 (D)

Pattern and Cutting Layout

All measurements are in centimeters (cm). The edges are left cut.

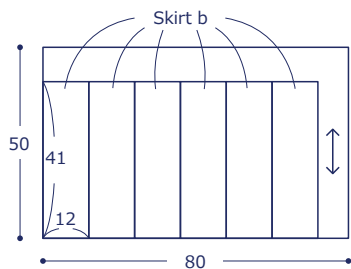
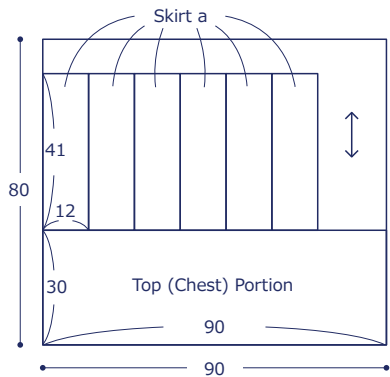

1. Make a skirt.

① With front/outer sides facing each other, piece together a and b. Serge the seam or run zigzag stitches on the seam.

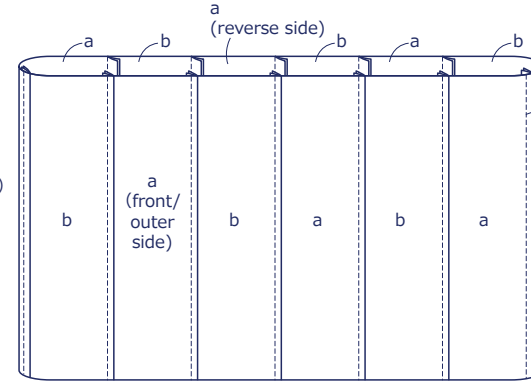
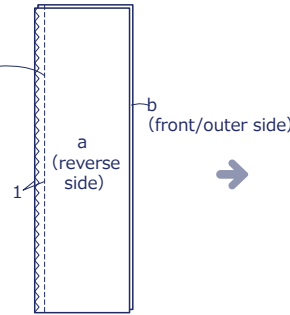

② As in Process ①, sew together all 12 pieces. Press down the seam to one side and run top stitches from the front.

Put the elastic tape (waist measurement + 1cm) through and sew to secure.

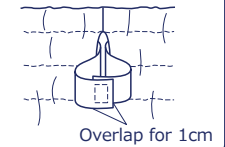

Overlap for 1cm

⑤ Put the elastic tape through four openings.

2. Prepare the top (chest) portion

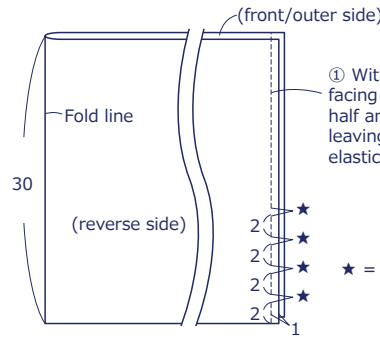

① With front/outer sides facing each other, fold in half and sew the end leaving openings for elastic tapes.

★ = Opening for elastic tapes 1.5

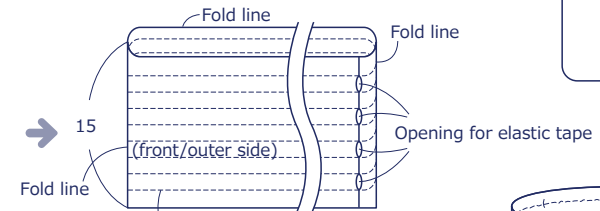

② With front/outer sides facing outside, sew and create the opening for elastic tapes at the same interval in the previous step.

③ As in the diagram, place the skirt and top portion and sew together. Serge or run zigzag stitches on the seam.

3. Sew together the skirt and top (chest) portion.

① With front/outer sides facing outside, fold the skirt in half. On the other side of the fold line, run rough stitches to make a gathering.

② Pull the thread from Process ① tightly to match the size with the top.

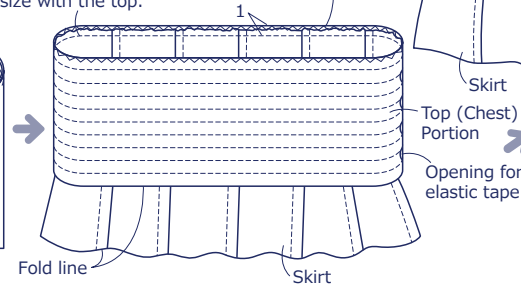
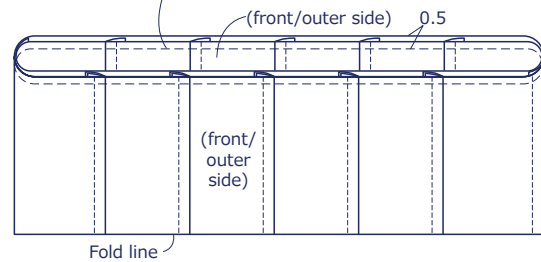

④ Press down the seam from Process ③ to the skirt side and run top stitches.