



Azuma Bukuro (Japanese Traditional Cloth Bag)

Design & work: Yuki Inomata

Size (when opened): about 51cm (l)
about 51cm (w)

Materials

- Fabric (Outer fabric A): 80cm×40cm
(Outer fabric B): 80cm×40cm
- Leather (Embellishment): 10cm×10cm
- Double sided rivets: One pair (0.7cm diameter)

Fabric shown for this sample: TSUMIKI PG101-1(A) (D)

Pattern and Cutting Layout

All measurements are in centimeters (cm).
Numbers in () denote seam allowance. All seam allowances
2cm unless otherwise stated.

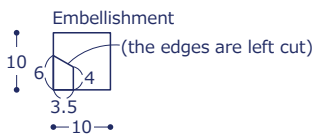
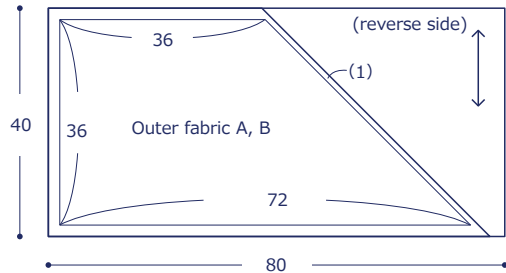

Instructions

1. Prepare the outer fabric.

① With front sides facing each other, sew together the outer fabrics A and B. Serge the seam.

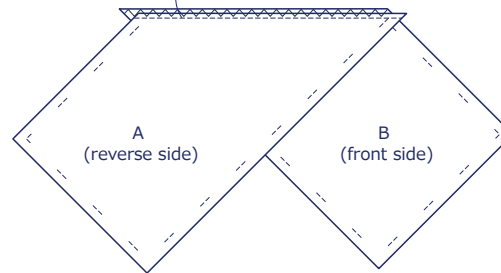

② Spread the fabric.
Cut off the excess seam.

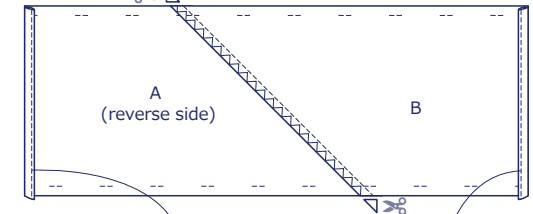

③ Double-fold both side seams and sew.

2. Make the bag.

① As shown, fold the fabric with front sides facing each other. Sew the top edge.

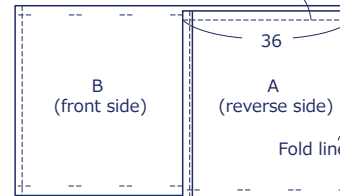

② Fold back A as shown.

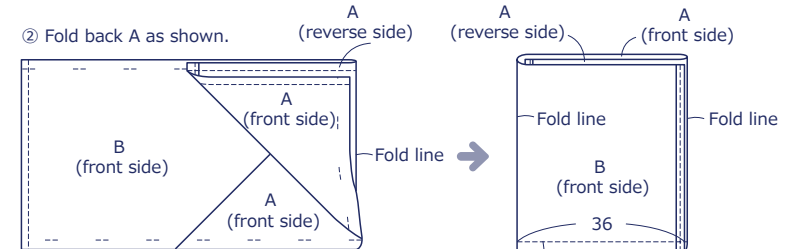

③ With front sides facing each other, fold B and sew the bottom edge.
(Be careful not to sew together the fabric folded back in process ②).

3. Finish the seam.

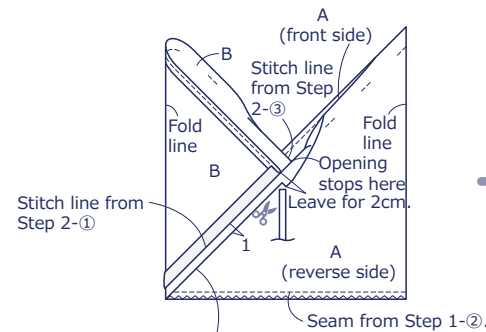

① Re-fold the bag as shown.
Cut the bottom seam from Steps 2-①,
② to right before the end of opening.

② Wrap the seam cut from process
① with the other seam.
Double-fold the seam of the opening
side and sew continuously.

4. Attach the embellishment.

① Turn the bag inside out.

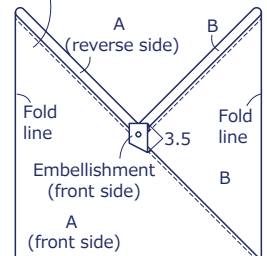

② Fold back the embellishment, with front side facing outside. Place one side of the opening edge in between. Check the balance and secure it using double-sided rivets.