



どんぐりむらのなかまたち Lesson Bag and Shoes Case Set

Design & work: Kokka Fabric

Size: about 30cm (l) x about 40cm (w)
about 28cm (l) x about 20cm (w)
※ Handles excluded

© Miwa Nakaya / Gakken Plus

Materials

- Outer fabric A: 110cm wide x 50cm
- Outer fabric B: 110cm wide x 20cm
- Lining fabric: 110cm wide x 70cm
- Fusible interfacing (medium thickness): 90cm wide x 70cm
- Flat tape: 25mm wide x 102cm
- D ring: 25mm wide x 1

Fabric shown for this sample: The Friends at the Acorn Village JG47100-2 (A)

Pattern and Cutting Layout

All measurements are in centimeters (cm).
Add 1cm seam allowance when you cut the fabric.

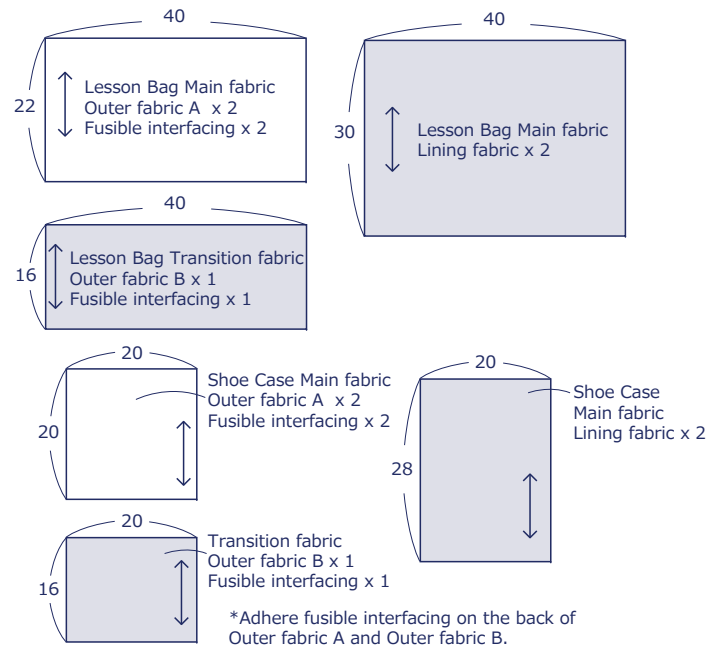

have fun with KOKKA fabric! produced by KOKKA

kokka-fabric.com

The craft projects and works featured in kokka-fabric.com are strictly for personal use and enjoyment.
Please refrain from selling handmade items using the same exact design (including the pieces made in different fabrics) featured in kokka-fabric.com.

Instructions

1. Sew together the main outer fabric and transition outer fabric

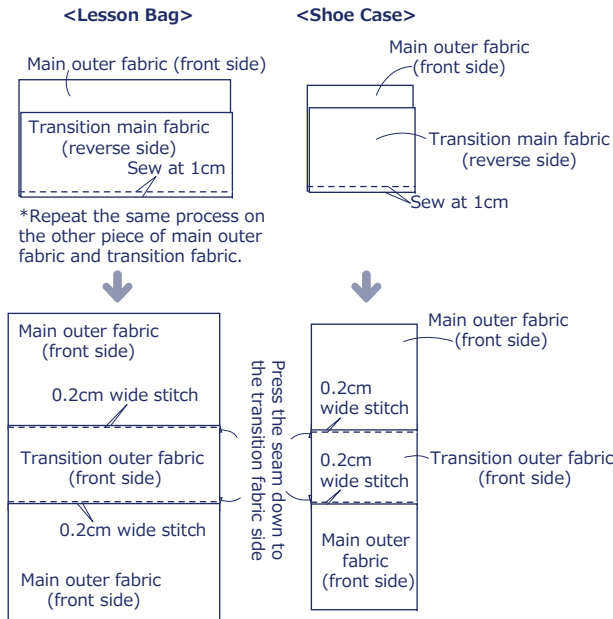

2. Baste the handle tape to the outer fabric

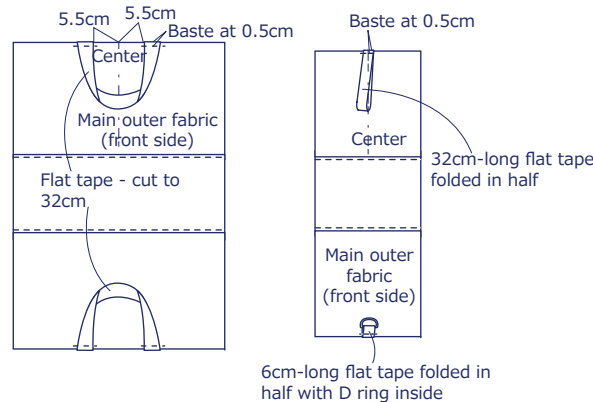

3. With the front sides facing each other, sew together the outer and lining fabrics together on the bottom and sides

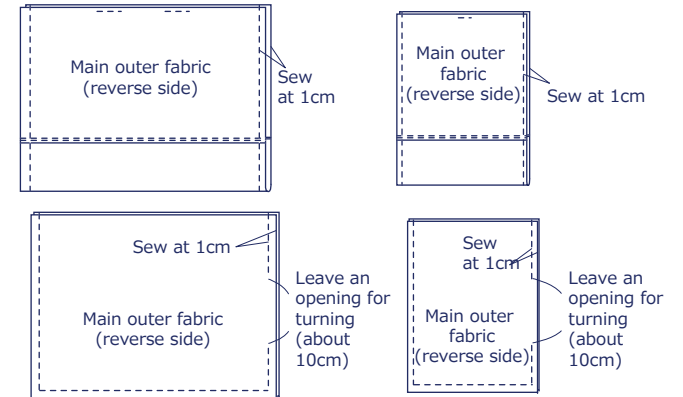

4. With the front sides facing each other, sew together the outer and lining fabrics at the top opening

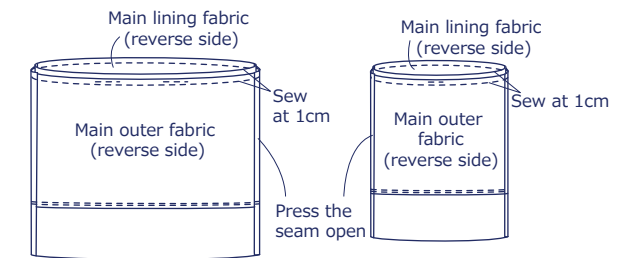

5. Using an opening for turning, turn the bag inside out. Run stitches at the top opening to finish

