



Tunic Dress

Design & work:
Yuka Yonekura (FRANCESCA AMAM LABEL)

Size: 76.5cm (length) for 140cm height

have fun with KOKKA fabric! produced by **KOKKA**

kokka-fabric.com

The craft projects and works featured in kokka-fabric.com are strictly for personal use and enjoyment.
Please refrain from selling handmade items using the same exact design (including the pieces made in different fabrics) featured in kokka-fabric.com.

Materials

- Fabric: 106cm wide x 2m
- Elastic tape: 1.2cm wide x 50cm

Fabric shown for this sample: naniIRO KOMOREBI/// JG10350 (D) Calm Joy

Pattern

All measurements are in centimeters (cm).

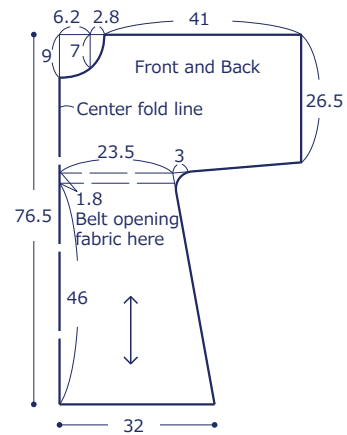

Cutting Layout

Numbers in () denote seam allowance.
The edges are left cut unless otherwise stated.

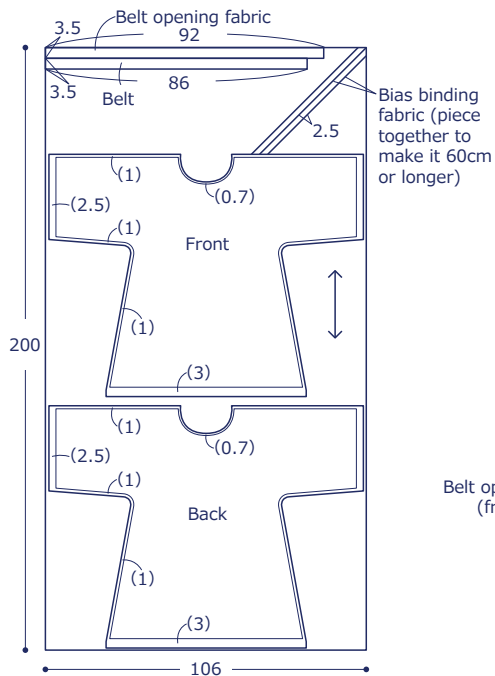

Instructions

Preparation

- ① Double fold the sleeve opening and hem. Iron to score a crease line (Refer to ③ and ⑤)
- ② Fold the belt, belt opening fabric and bias binding strip. Iron to score a crease line. (Refer to ②, ④ and ⑥)
- ③ Fold where the belt opening will be attached and iron to score on the front and back.

1. Open the seam from Preparation 1. With the front sides facing each other, sew together the shoulder, underarm and sides. Serge the seam and press it down to the backside.

2. Finish the neckline using a bias binding strip.

② ① Fold the long end of the bias binding strip (preparation)

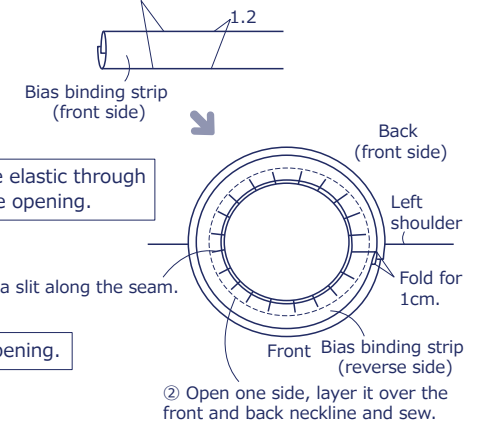

5. Put the elastic through the sleeve opening.

③ Cut a slit along the seam.

4. Make the belt opening.

6. Make the belt and put it through the belt opening.

① With the front sides facing outside, fold in four (preparation).

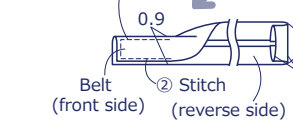

3. Double fold the hem and run stitches.

④ ① Fold the long end of the belt opening fabric (preparation)

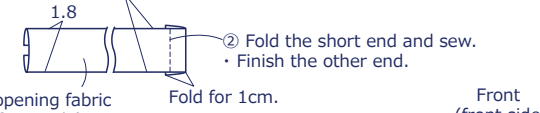

③ Place the belt opening fabric in the front and back and sew. (Start from the back center.)

