



Sailor Collar Kid's Blouse

Design & work: Kokka Fabric

Size: 110cm size

The craft projects and works featured in kokka-fabric.com are strictly for personal use and enjoyment.
Please refrain from selling handmade items using the same exact design (including the pieces made in different fabrics) featured in kokka-fabric.com.

Materials

- Outer Fabric: 108cm wide × 120cm
- Fusible interfacing (thin): 90cm wide × 30cm

Fabric shown for this sample: P43100-100 (c)

Pattern

Unit: cm []: Seam

When cutting the fabric, add 1cm seam unless otherwise stated.

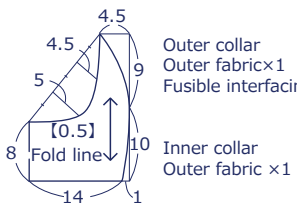
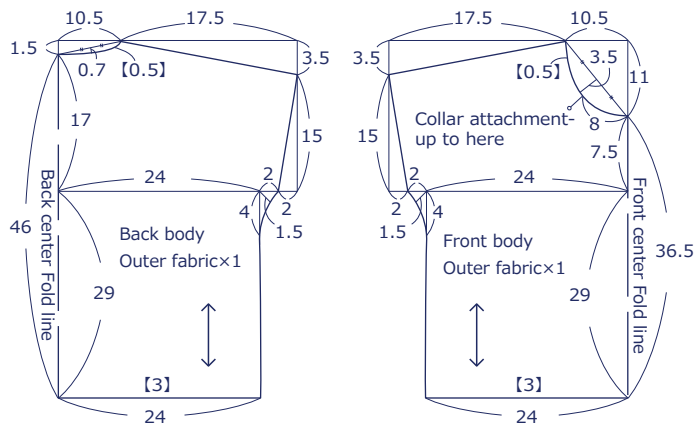

※ Adhere fusible interfacing on the back of the outer collar.

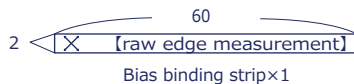

※ If a single fabric is too short, piece together two fabrics to make a strip.

作り方

1. Run zigzag stitches on the shoulder seam. With the front sides facing each other, sew together the front and back bodies at the shoulder.

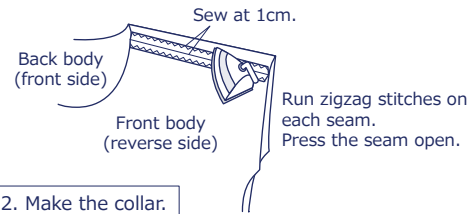

2. Make the collar.

With the front sides facing each other, sew together the front and back collar around the perimeter.

Turn it inside out and run stitches.

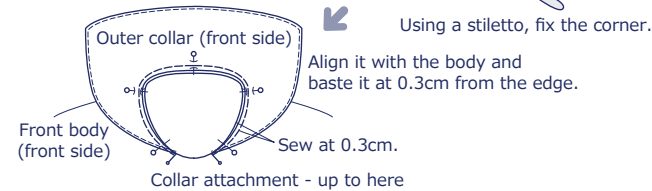
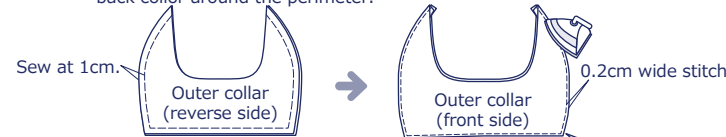

3. Finish the neckline.

Fold both long ends of the bias binding strip for 0.5cm using an iron.

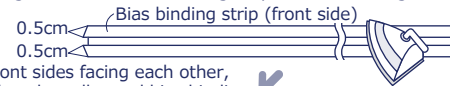

With the front sides facing each other, sew together the collar and bias binding strip. Cut off excess strip.

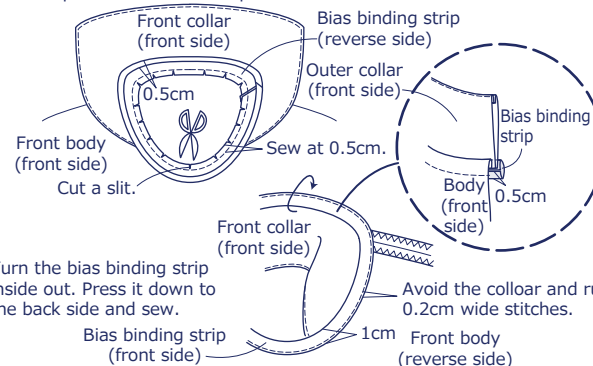

Turn the bias binding strip inside out. Press it down to the back side and sew. Avoid the collar and run 0.2cm wide stitches.

4. With the front sides facing each other, sew together the sleeve and body.

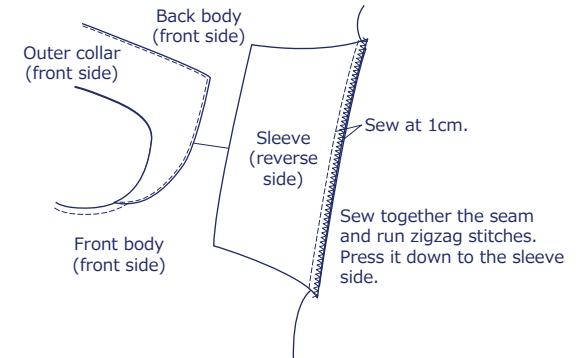

5. Sew under the sleeves and sides.

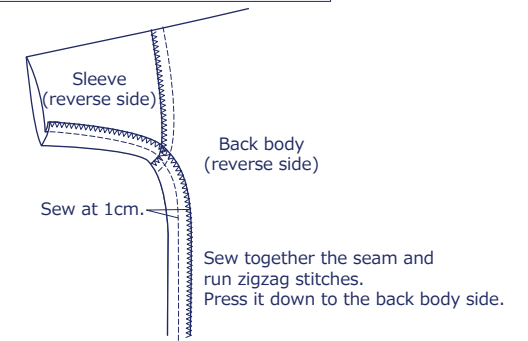

5. Finish the sleeve opening and hem.

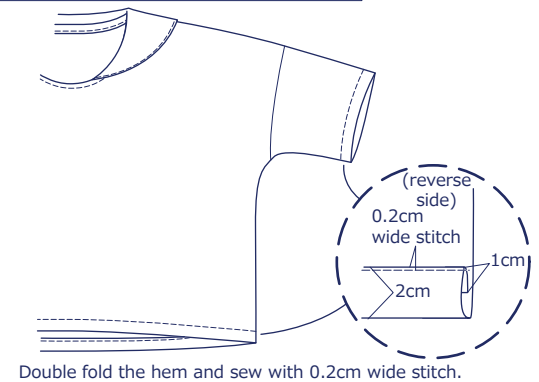

Double fold the hem and sew with 0.2cm wide stitch.