



Round Bottom Bag

Design & work: Kokka Fabric

Size: About 25cm (l) About 42.5cm (w)
About 27cm (bottom) (Handle excluded)

Materials

- Outer fabric: 110cm wide × 60cm
- Lining fabric: 90cm wide × 50cm
- Fusible interfacing (Thick): 110cm wide × 75cm
- Flat tape (4.5cm wide): 92cm

Fabric shown for this sample: H11500-501 (A)

Pattern and Cutting Layout

Unit: cm
Add 1cm seam allowance when cutting the fabric.

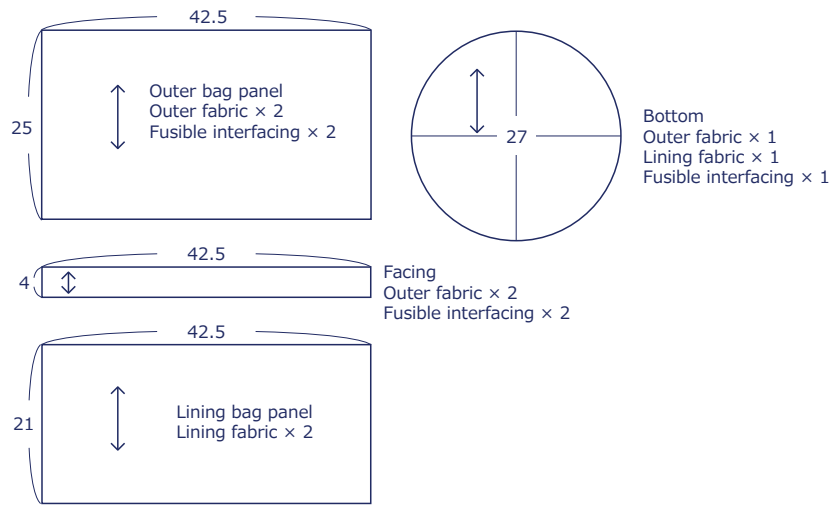

※ Adhere fusible interfacing on the back of all the outer fabrics.

have fun with KOKKA fabric! produced by **KOKKA**

kokka-fabric.com

The craft projects and works featured in kokka-fabric.com are strictly for personal use and enjoyment.
Please refrain from selling handmade items using the same exact design (including the pieces made in different fabrics) featured in kokka-fabric.com.

Instructions

1. With the front sides facing each other, piece together the facing and lining panel fabric.

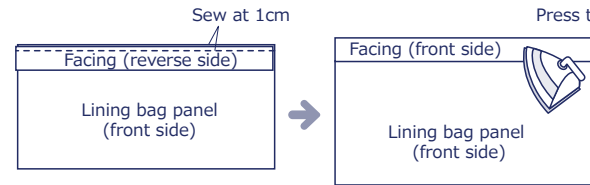

4. With the front sides facing each other, sew together the outer bag and lining bag at the opening.

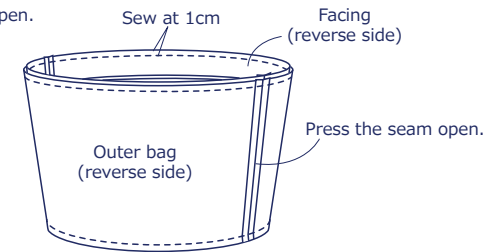

2. With the front sides facing each other, sew together the sides of the outer bag panel fabric and lining bag panel fabric respectively.

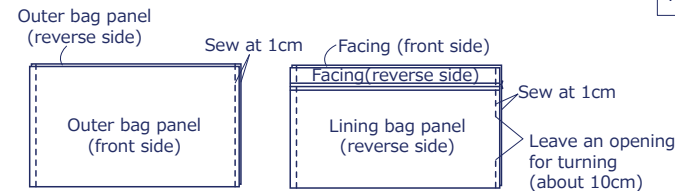

5. Turn the bag inside out using an opening for turning. Apply stitching around the top opening.

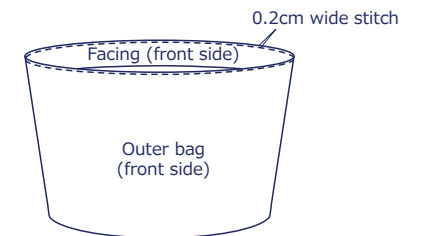

※ Close the opening for turning.

3. With the front sides facing each other, sew together the bag panel and bottom.

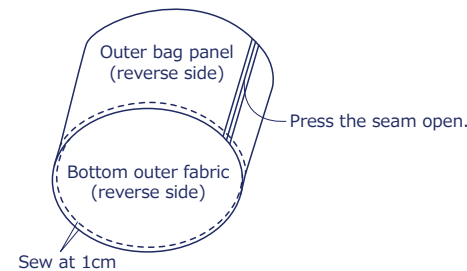

※ Repeat the process for lining fabric.

6. Attach the handle to finish.

