



Fluffy Drawstring Bag in Double Gauze Fabric

Design & Work: Satomi Takei(tournesol*)

Size: 22.5cm (l – excludes opening fabric)
20cm (w – at the opening) 3cm (d)

Materials (for one bag)

- Fabric (Outer fabric, Lining fabric): 50cm×50cm
(Bottom fabric (Lace material)): 30cm×20cm
(Opening fabric): 20cm×10cm
- Tape: 1.5m (width 1cm)

Fabric shown for this sample: (Outer fabric, Lining fabric) PAINT by ellen baker JG42020-21A (White), JG42020-21B(Dark blue)

Pattern & Cutting Layout

Unit: cm. All raw edge.

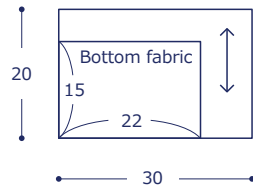
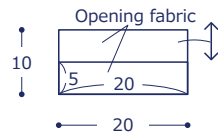
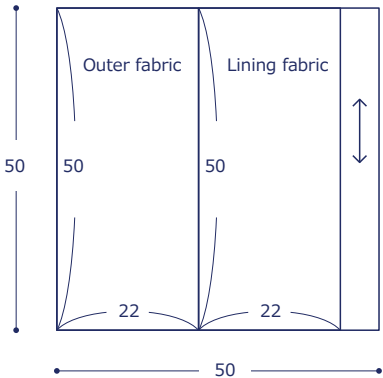

Instructions

1. Make the outer bag.

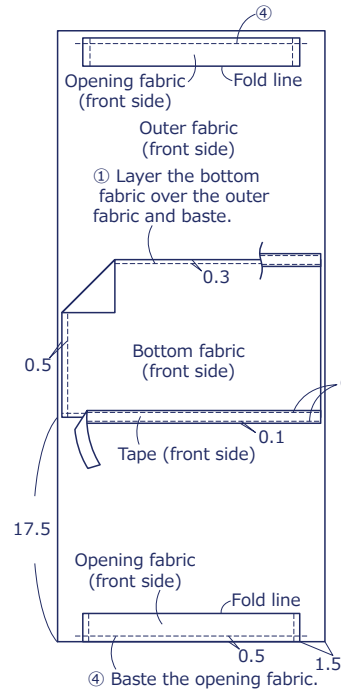

2. Make the lining bag.

Make the lining bag following Step 1 process ⑤ and ⑥. (In process ⑤, leave an opening for turning for 7cm.)

③ Make the opening fabric.

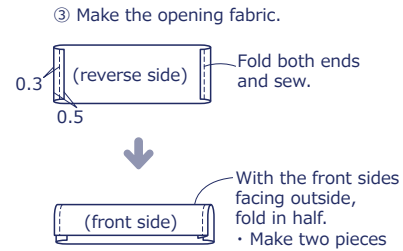

3. Finish the bag.

① With the front sides facing each other, sew together the outer and lining bags at the top opening.

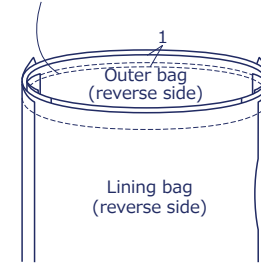

② Turn it inside out and close the opening for turning.

