



Sacoche

have fun with KOKKA fabric! produced by **KOKKA**

kokka-fabric.com

The craft projects and works featured in kokka-fabric.com are strictly for personal use and enjoyment. Please refrain from selling handmade items using the same exact design (including the pieces made in different fabrics) featured in kokka-fabric.com.

Design & work: Masumi Saito (sinafuku)

Size: 28cm (l) 30cm (w) 10cm (d)

Materials

- Fabric (Bag panel, Shoulder strap): 110cm wide×90cm
(Pocket): 30cm×30cm
- Tape: 1.6cm wide×40cm
- Velcro: 2cm wide×3cm

Fabric shown for this sample: H12000-201C

Pattern and Cutting Layout

Unit: Centimeters (cm) All raw edge.

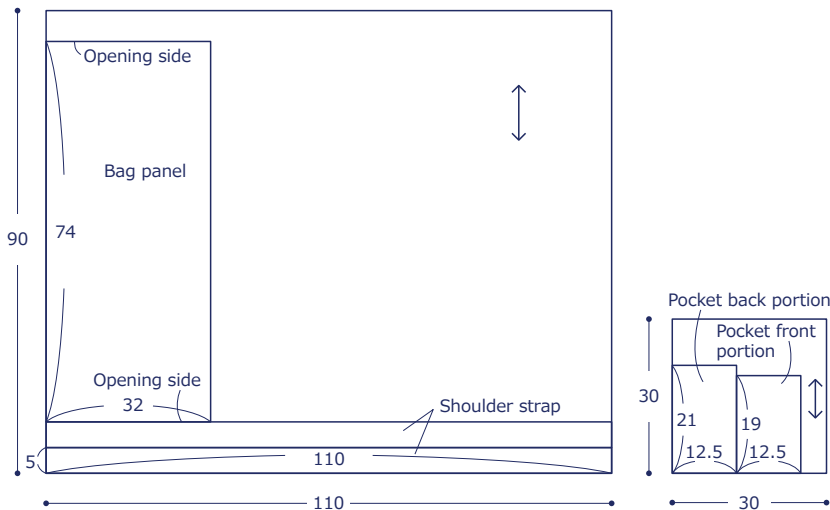

Instructions

1. Make the pocket.

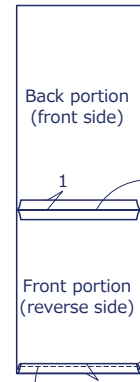

② Put together the front portion and back portion and sew together at the bottom.

① Double fold the pocket opening and sew.

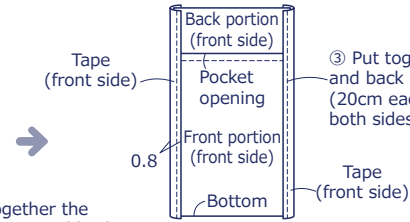

③ Put together the front portion and back portion and fold the tape (20cm each) in half. Wrap around both sides with the tape and sew.

2. Make the shoulder strap.

Fold the long ends. With the front sides facing outside, sew together two pieces.

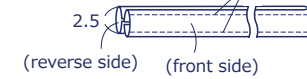

3. Make the bag.

① Double fold the opening and sew. (Insert the pocket on one side.)

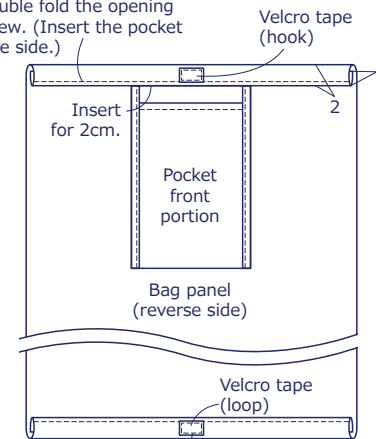

② Sew velcro tape onto the fabric.

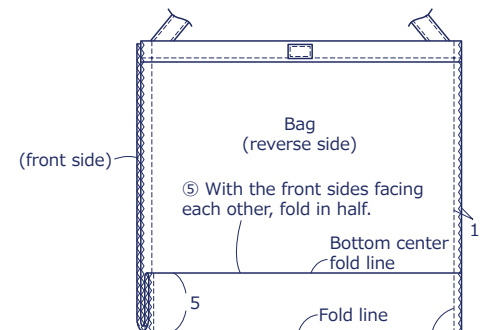

⑤ With the front sides facing each other, fold in half.

Bottom center fold line

Fold line

⑥ Fold the gusset.

⑦ Sew both sides.

③ Baste the shoulder strap.

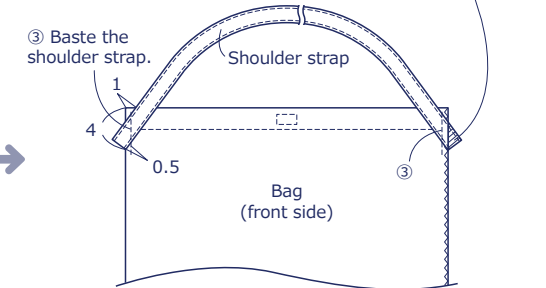

④ Cut the excess strap and finish the edge on both sides.

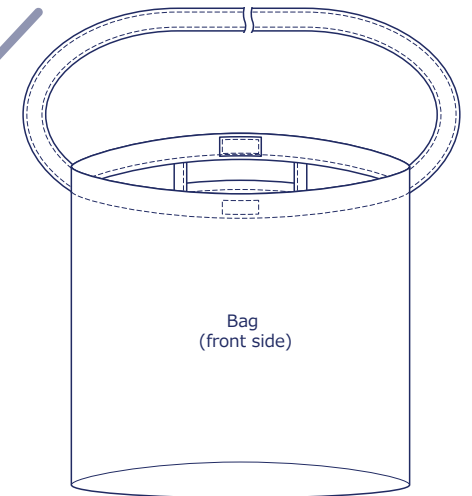

⑧ Turn it over and align the shape.