



Kid's Bustier-Style Tops

Design & work: Naomi Nohara (lepolepo)

Size: For 110cm height

have fun with KOKKA fabric! produced by KOKKA

kokka-fabric.com

The craft projects and works featured in kokka-fabric.com are strictly for personal use and enjoyment. Please refrain from selling handmade items using the same exact design (including the pieces made in different fabrics) featured in kokka-fabric.com.

Materials

- Fabric: 110cm wide x 50cm
- Elastic tape: 30cm (1cm wide)
- Buckle, O ring: 2 pieces each (1cm inside diameter)

Fabric shown for this sample: LO36060-2D

Pattern and Cutting Layout

Unit: cm (): Seam allowance.

Add 1cm seam allowance unless specified otherwise.

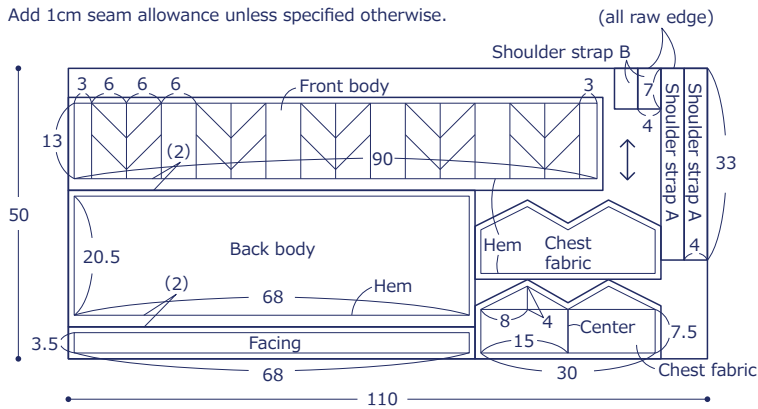

Instructions

① Apply zigzag stitches on the hem of the chest lining fabric and front and back bodies.

