



Gathered Skirt with Yoke

Design & Work: Anriko

Size: Skirt length 70cm

Materials

- Fabric: 110cm wide×1.8m
- Braided Elastic: 1.8m (6 cord)
- Piping cord: 105cm (for piping width of 0.3cm)

Fabric shown for this sample: (Yoke, Front and Back Skirt)
IHME CHAMBER EEA-2002-1A

Pattern and Cutting Layout

Unit: cm. All raw edge.

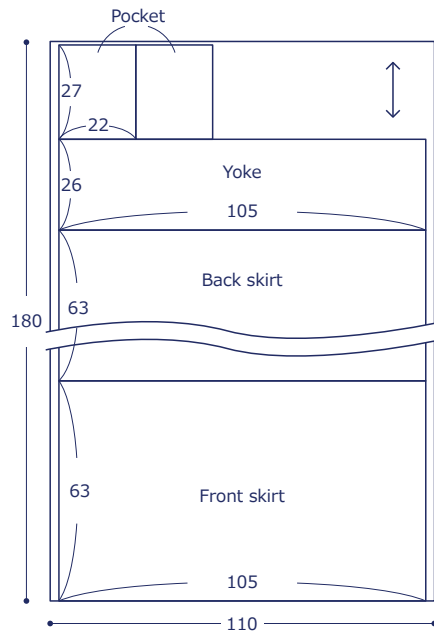

have fun with KOKKA fabric! produced by KOKKA

kokka-fabric.com

The craft projects and works featured in kokka-fabric.com are strictly for personal use and enjoyment. Please refrain from selling handmade items using the same exact design (including the pieces made in different fabrics) featured in kokka-fabric.com.

Instructions

1. Make the pocket

② Fold the top opening of the pocket in three and sew.

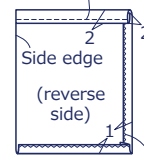

① Apply zigzag stitches on the edge of the fabric except the top opening and side edge. Fold the fabric.

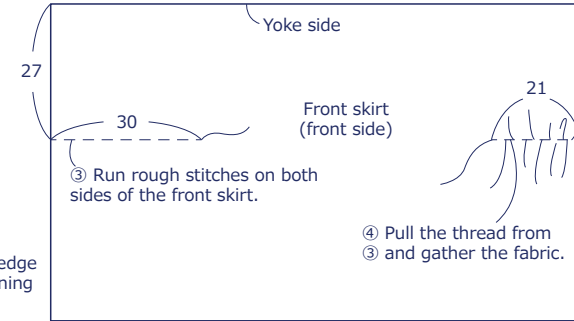

④ Pull the thread from ③ and gather the fabric.

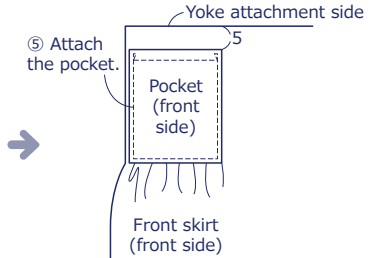

⑥ Pull the thread from ④. Attach the other piece following the same process.

• Make one piece each as a mirror image.

2. Make the skirt

① Apply zigzag stitches on the edge of the front and back skirts at the Yoke attachment side.

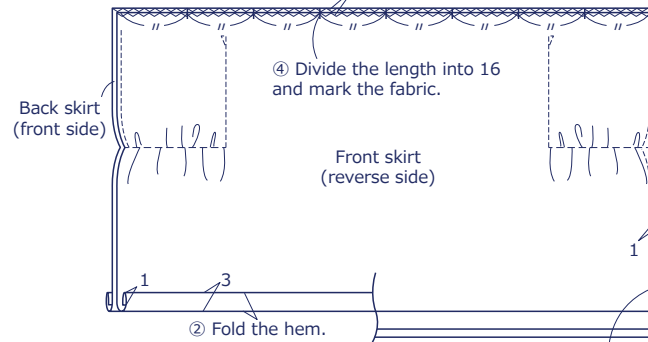

④ Divide the length into 16 and mark the fabric.

② Fold the hem.

3. Make the yoke

② With the front sides facing outside, fold in half.

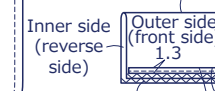

① Apply zigzag stitches on the long end of the fabric.

③ Open ②. Baste the piping tape to the outer side.

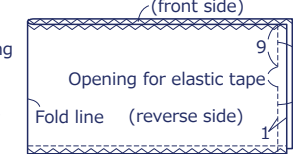

⑤ With the front sides facing outside, fold in half.

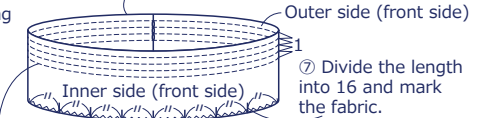

⑥ Apply stitches.

4. Finish the skirt

① Run rough stitches on the yoke attachment side of the skirt.

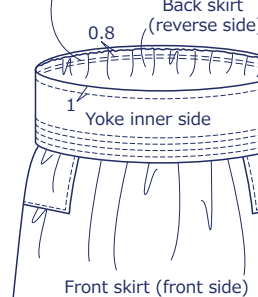

② Layer the yoke and skirt. Pin them together. Pull the thread from ① and gather the fabric.

③ Sew together the yoke and skirt.

④ Press the seam from ③ to the yoke side and run stitches.

⑥ Put through the elastic tape (3 pieces, 60cm each) and tie the end.

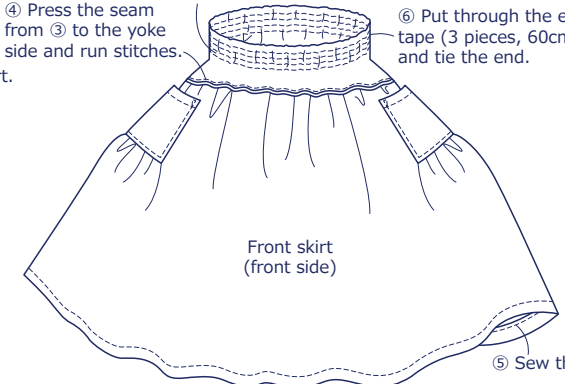

⑤ Sew the hem.

※ Process for zigzag stitches for [2]-① and [3]-① is not shown here.