



Bucket Shaped Bag

Design & work: Kokka Fabric

Size: About 28cm (l) x 36cm (w) x 18cm (d)

Materials and Tools

- A Fabric: 110cm wide x 40 cm
- B Fabric: 110cm wide x 50 cm
- Fusible interfacing: 100cm wide x 50 cm
- Zipper: One piece (30cm long)
- Flat tape: 60cm (4.5cm wide)

Fabric shown for this sample: YKA-59020-2B

Pattern

Unit: cm. All seam allowance - 1cm. Add seam allowance when cutting the fabric.

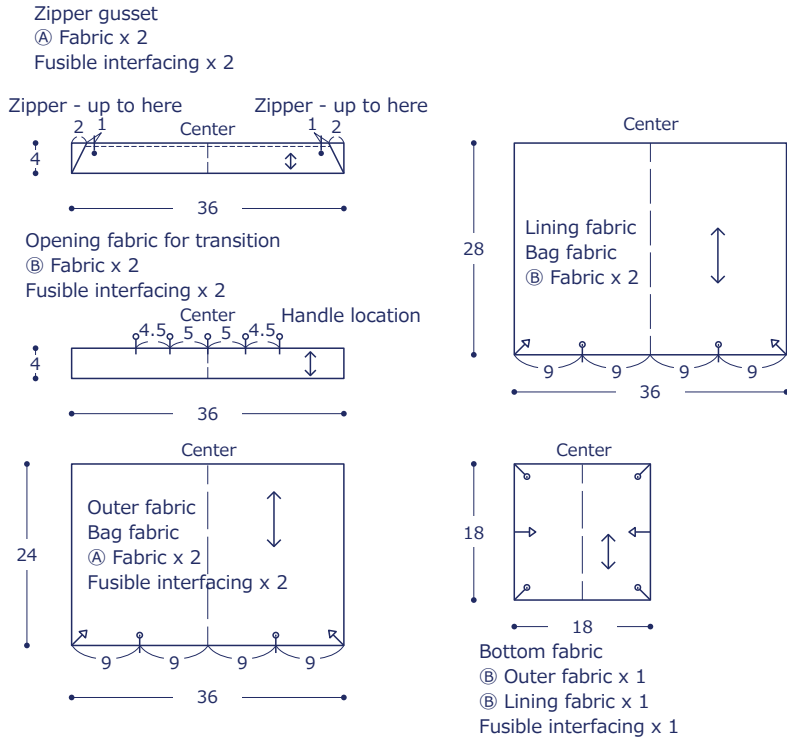

Instructions

- ① Adhere fusible interfacing on the back of the Zipper gusset, Opening transition fabric and Outer bag fabric.
- ② Sew together the opening transition fabric and outer bag fabric. Make the handle and baste it to the bag fabric.

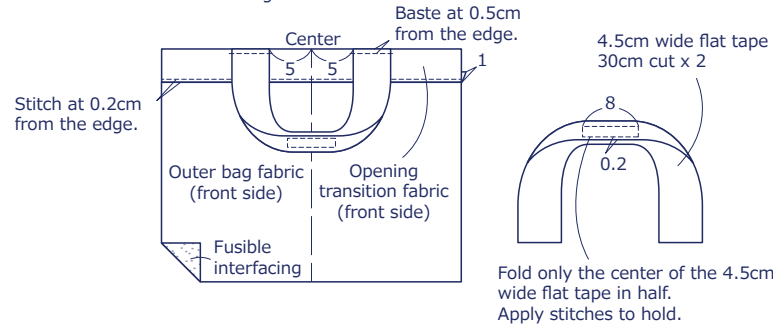

- ③ Sew together the sides of the outer bag and lining bag respectively.

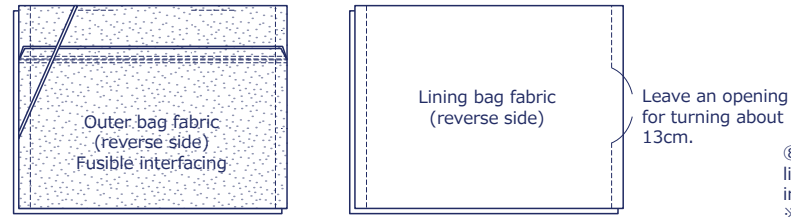

- ④ Sew together the bag fabric and bottom fabric (Repeat the process for lining fabrics).

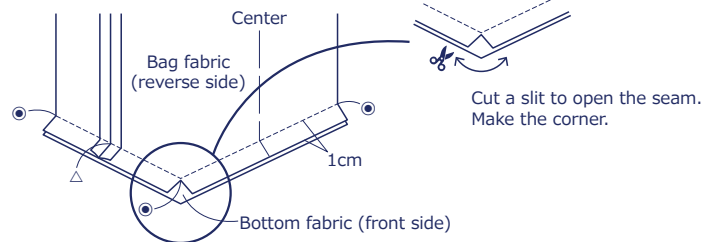

- ⑤ Apply zigzag stitches around the zipper gusset and piece together with the zipper.

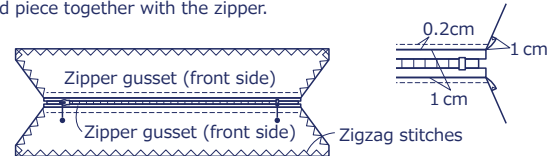

- ⑥ Sew the side of the zipper gusset.

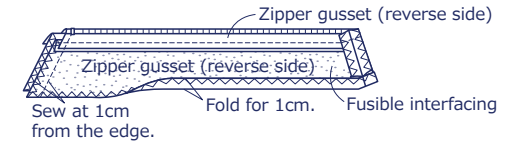

- ⑦ With the front sides facing each other, layer the outer bag opening and lining bag opening and sew together.

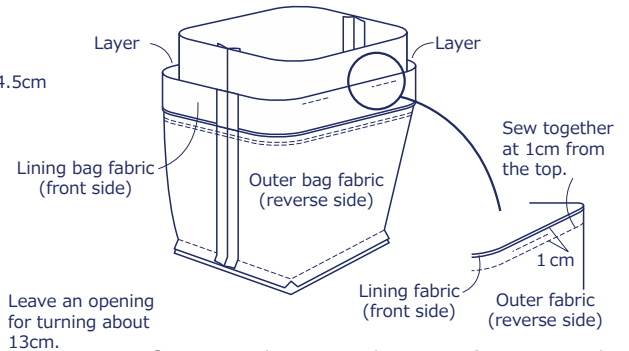

- ⑧ Turn it inside out using the opening for turning on the lining fabric. Align the shape of the top opening using an iron. Sew the zipper gusset in line with the top opening. * Close the opening for turning on the lining fabric.

