



# Long Flair Skirt

Design & Work: Anriko

Size: Length 81cm

have fun with KOKKA fabric! produced by KOKKA

[kokka-fabric.com](http://kokka-fabric.com)

The craft projects and works featured in kokka-fabric.com are strictly for personal use and enjoyment. Please refrain from selling handmade items using the same exact design (including the pieces made in different fabrics) featured in kokka-fabric.com.

## Materials

- Fabric: 110cm wide x 2m
- Elastic tape: 65cm (2.5cm wide) – Adjust the length to your size.

Fabric shown for this sample: EKXA-5300D/#2 C

## How to make a pattern

Unit: cm

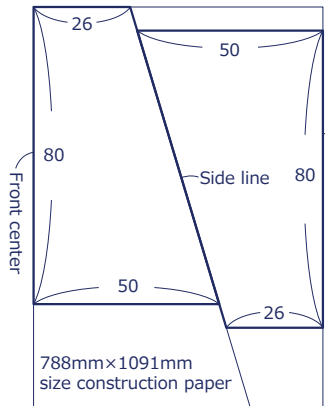

① Cut two pieces of trapezoid.

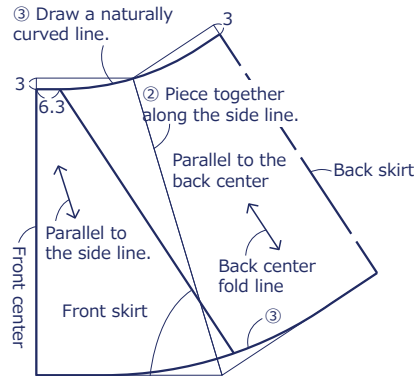

④ Draw a transition line parallel to the back center.

## Cutting Layout

Numbers in ( ) denote seam allowance.  
Add 1cm seam allowance unless specified otherwise.

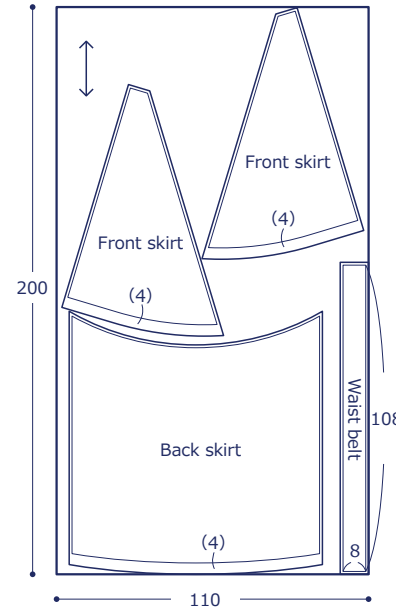

## Instructions

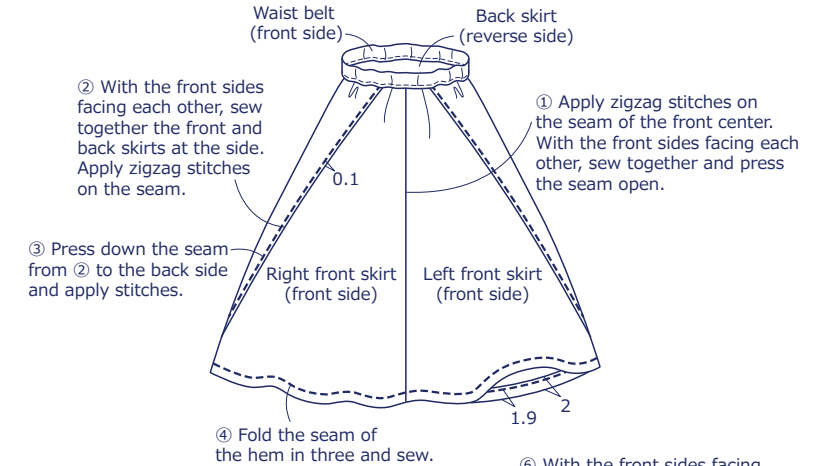

- ① Apply zigzag stitches on the seam of the front center. With the front sides facing each other, sew together and press the seam open.
- ② With the front sides facing each other, sew together the front and back skirts at the side. Apply zigzag stitches on the seam.
- ③ Press down the seam from ② to the back side and apply stitches.
- ④ Fold the seam of the hem in three and sew.

⑤ Make the waist belt.



a. Fold the seam.

c. With the front sides facing each other, fold in two. Sew the sides, leaving an opening for elastic tape.

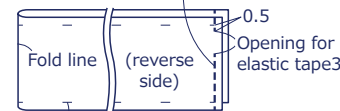

b. Open the seam from a.

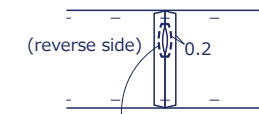

d. Press the seam from c open. Apply stitches around the opening for the elastic tape.

e. Sew together the skirt and waist belt.

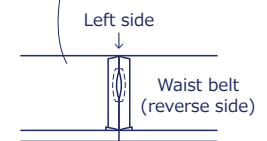

f. Fold the seam from a open.

Back skirt (reverse side)

⑥ With the front sides facing outside, fold the waist belt and sew together.

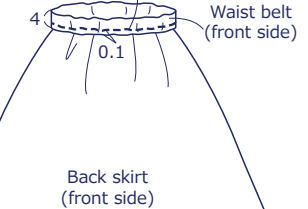

Back skirt (front side)

⑦ Put through the elastic tape.

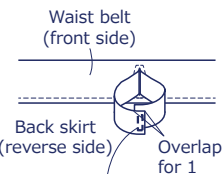

Put through the elastic tape and sew.