



Kid's Dress

Design & work: Kokka Fabric

Size: 100cm

Materials

- Outer fabric: 108cm wide x 90cm
- Flat elastic tape: about 6mm wide x 18cm

Fabric shown for this sample: Natural Life YRA-99000-1A

Pattern

Unit: Centimeters (cm) []: Seam allowance
When cutting the fabric, add 1cm seam allowance unless specified otherwise.

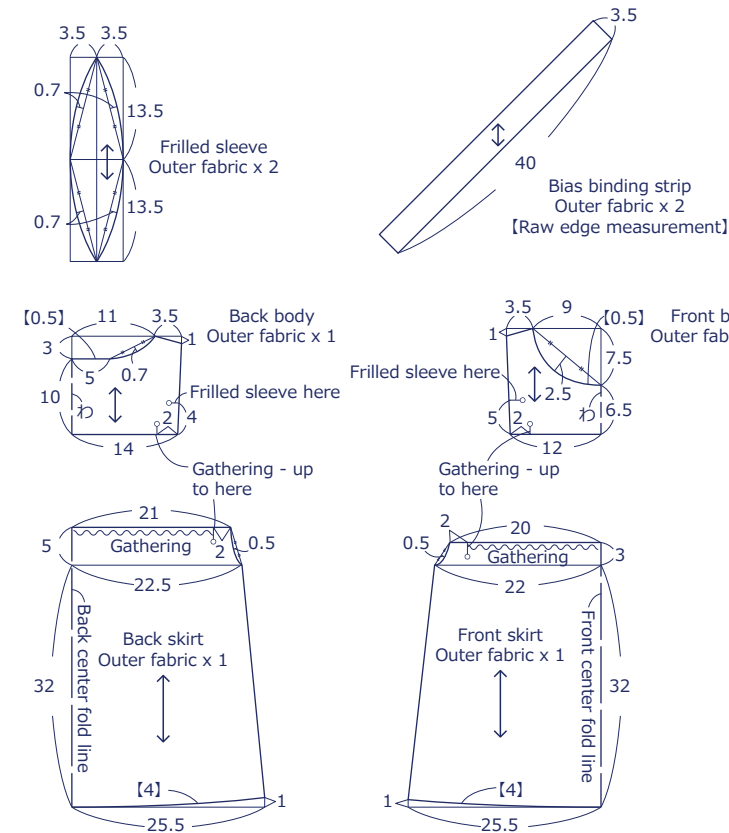

Instructions

1. Apply zigzag stitches on the shoulder of the body, side of the skirt and the seam of the armhole.

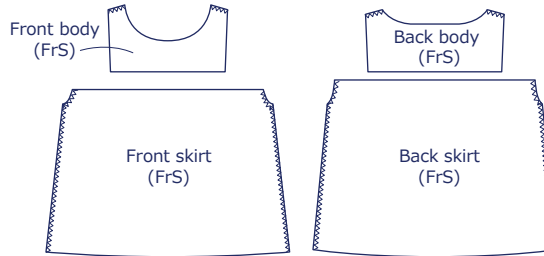

2. Sew the shoulder of the front and back bodies

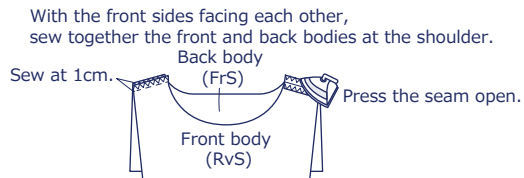

3. Make the frilled sleeves and attach them to the body

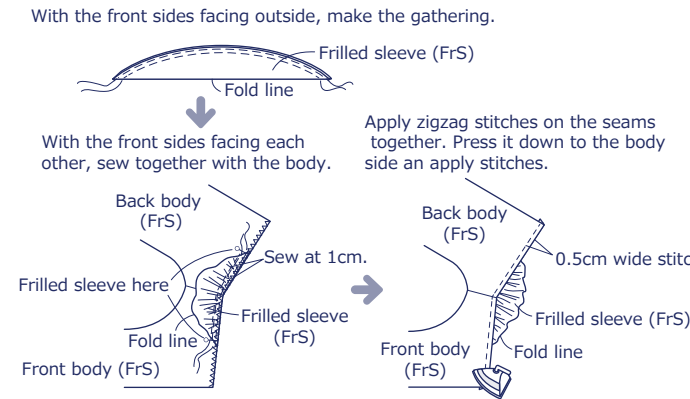

4. Sew the armhole of the skirt and sides

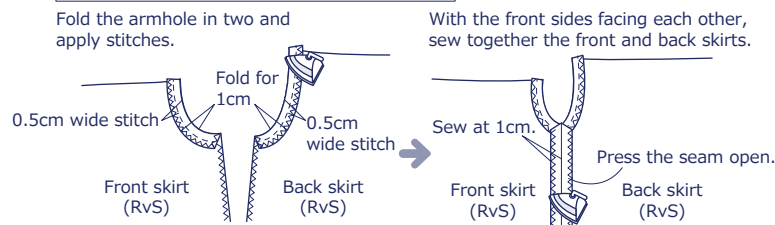

5. Sew together the body and skirt

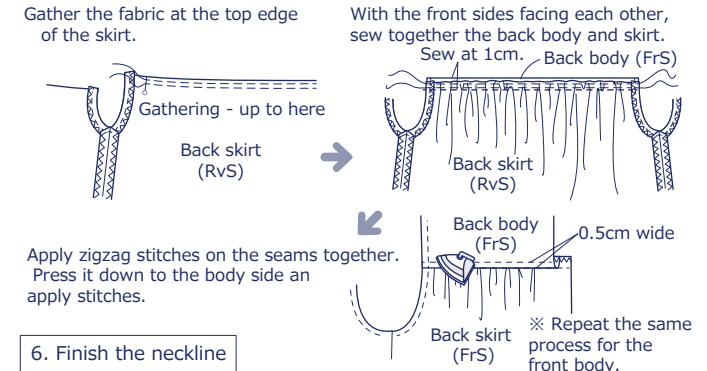

6. Finish the neckline

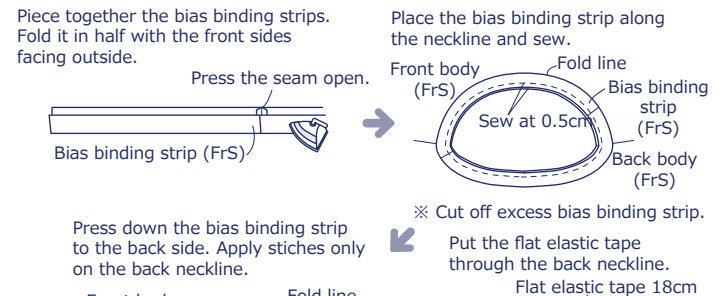

Press down the bias binding strip to the back side. Apply stitches only on the back neckline.

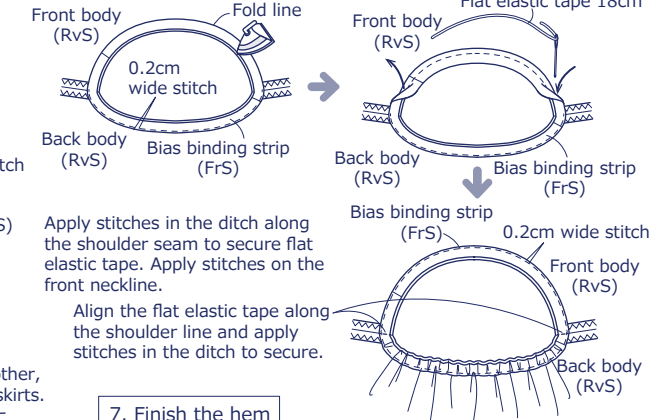

7. Finish the hem

