



Boat Shaped Tote Bag

Design & Work: Yui Tamaki

Size: 18 (l) 48cm (W) 12cm (d-maximum)

Materials

- Fabric (Outer Fabric): 100cm×50cm
(Lining Fabric(Leather-Like Felt)): 100cm×50cm
- Handle: 1 pair (Total length: 48cm)
- Rivet: 16 pairs (1cm diameter)

Fabric shown for this sample: (Outer Fabric) KATSUNO EKX-200-2C

Pattern and Cutting Layout

Unit: cm. Add 1cm seam.
Same cutting layout for the lining fabric.

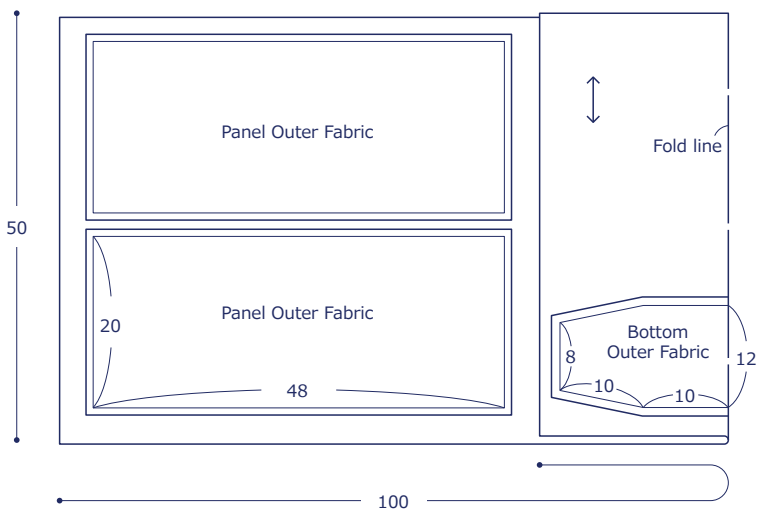

have fun with KOKKA fabric! produced by KOKKA

kokka-fabric.com

The craft projects and works featured in kokka-fabric.com are strictly for personal use and enjoyment. Please refrain from selling handmade items using the same exact design (including the pieces made in different fabrics) featured in kokka-fabric.com.

Instructions Front Side - (FrS), Reverse Side (RvS)

1. Make the outer bag

① With the front sides facing each other, sew together the panel outer fabrics at the sides.

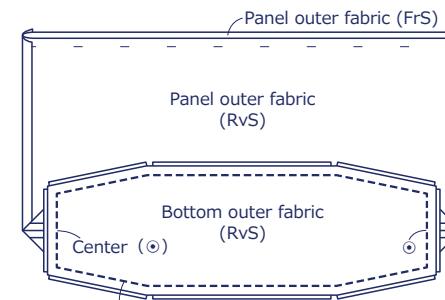
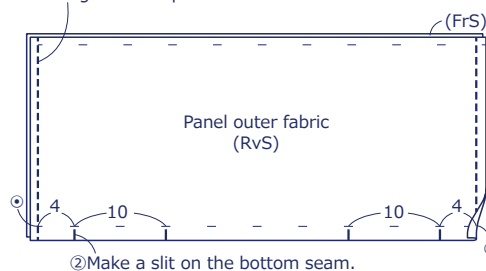

③ With the front sides facing each other, sew together the portion from ② and bottom outer fabric.

3. Piece together the outer bag and lining bag

① With the front sides facing each other, sew together the outer bag and lining bag at the top opening.

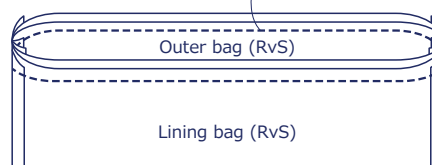

② Turn it inside out and close the opening.

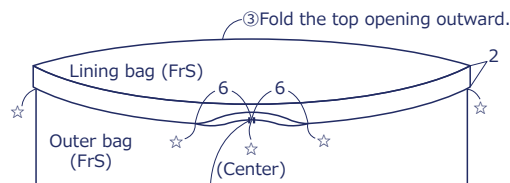

2. Following the steps in ①, make the lining bag

On step ①, leave an opening (10cm) on one side for turning.

⑤ Attach the handles using rivets.

