



# Long Flared Skirt

Design & Work: Kokka Fabric

Size: Medium

have fun with KOKKA fabric! produced by KOKKA

[kokka-fabric.com](http://kokka-fabric.com)

The craft projects and works featured in kokka-fabric.com are strictly for personal use and enjoyment. Please refrain from selling handmade items using the same exact design (including the pieces made in different fabrics) featured in kokka-fabric.com.

## Materials

- Outer Fabric: 100cm wide x 350cm
- Fusible Interfacing (light weight): about 20cm(L) x about 50cm(W)
- Elastic Tape (3cm wide): 32cm x one piece

Fabric shown for this sample: YKA-16000-1E

## Pattern

Unit: cm. ○ denotes specified measurements. Add 1cm seam allowance unless specified otherwise. Add seam when cutting the fabric.  
\*Seam finish - serge or zigzag stitches

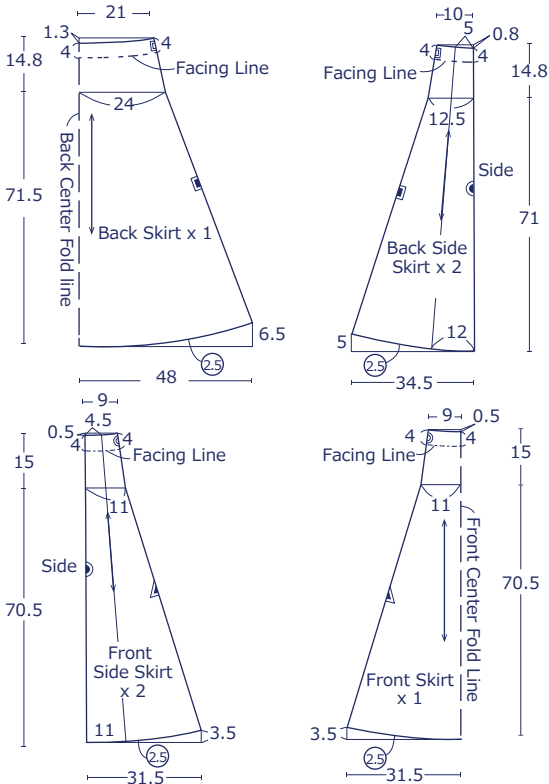

\*Trace front and back facings respectively and make the pattern as shown.

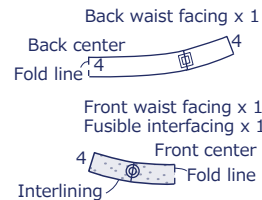

## Instructions

Front Side - (FrS), Reverse Side - (RvS)

1. Sew together the sides of the front and back skirts. Single fold the hem and apply stitches

① With the front sides facing each other, sew together the front and back side skirts at the side and finish the seam.

② Fold the hem and finish the seam. Apply stitches.

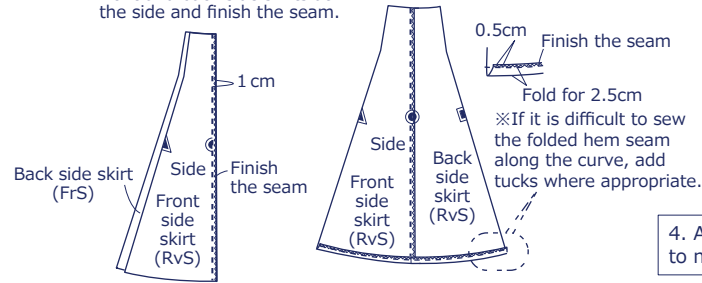

2. Fold the hem of the front and back skirts and apply stitches

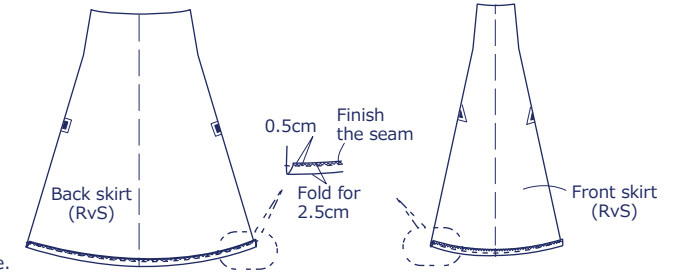

3. Sew together the front and back skirt and front and back side skirt. Finish the corner of the seam on the hem

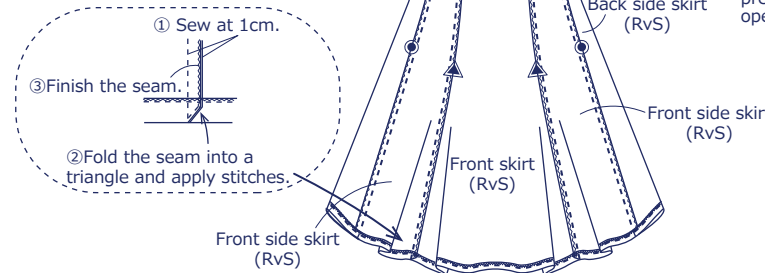

4. Adhere fusible interfacing on the back of the front waist facing to make the waist facing. Sew it onto the waist of the skirt

① Sew the side of the front and back waist facing. Make an opening for elastic tape on the left side.

② Iron and fold the end of the facing.

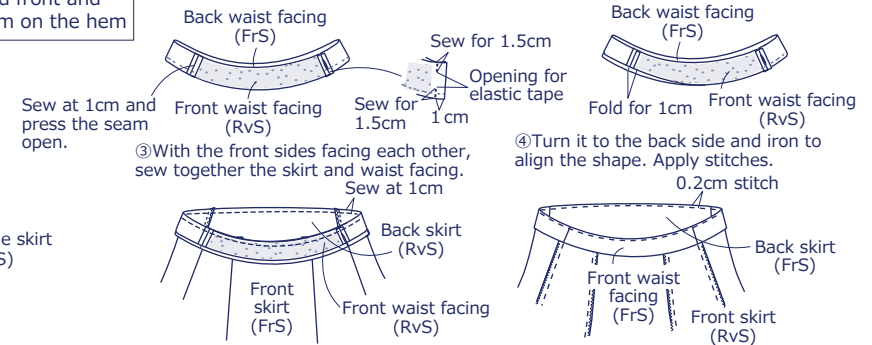

6. Pull the salvage cord from one side of the opening for elastic. Adjust the length and sew to secure

5. Attach the cord (about 50cm) made from the selvage to the end of the cut elastic tape. Place one side of the elastic in between and sew to secure

