



Tube-Style Pouch

Design & work: Satomi Takei

Size: 21cm (l) 10cm (diameter)

Materials

- Fabric (Body, Handle, Tab): 110cm wide x 30cm
- Fabric (Gusset): 25cm x 15cm
- Fusible Interfacing (medium weight) (RakuHari Presion Interfacing): 50cm x 30cm
- Zipper: 20cm x one piece
- Plsnap Snap Button: 1cm diameter x one pair
- Rivet: 0.7cm diameter x two pairs

Fabric shown for this sample (Body, Handle, Tab): EGXA-8800-2A-CA

Pattern

Unit: cm All raw edge

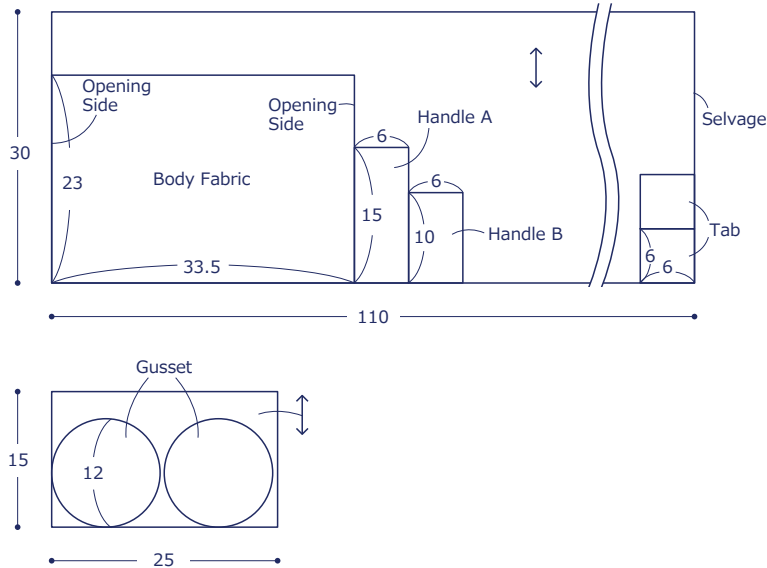

have fun with KOKKA fabric! produced by KOKKA

kokka-fabric.com

The craft projects and works featured in kokka-fabric.com are strictly for personal use and enjoyment. Please refrain from selling handmade items using the same exact design (including the pieces made in different fabrics) featured in kokka-fabric.com.

Instructions Front Side - (FrS), Reverse Side (RvS)

1. Adhere fusible interfacing

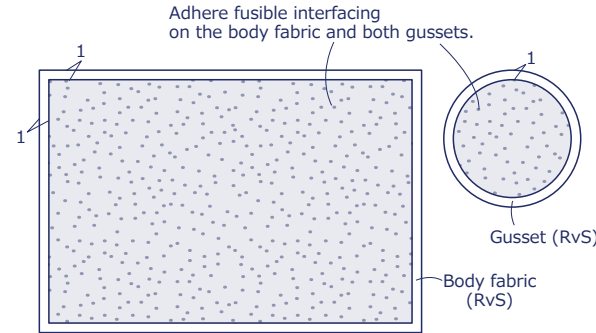

2. Attach the zipper

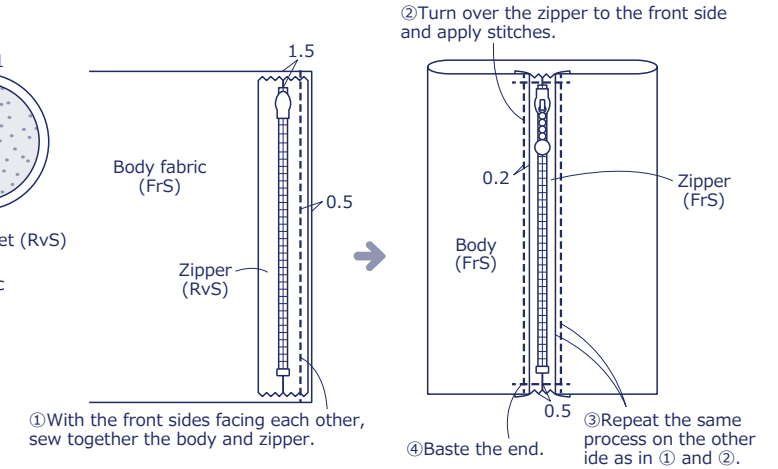

3. Make the tab

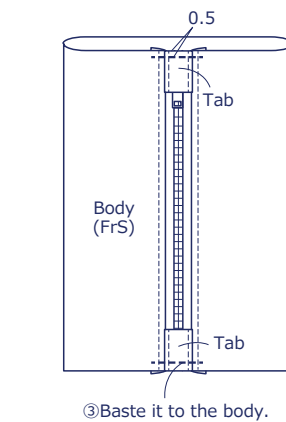
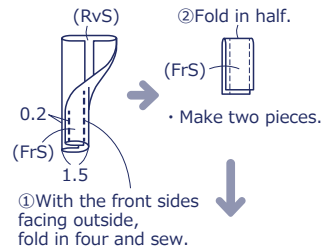

4. Make the tube body

① With the front sides facing each other, sew together the body and gusset with the zipper open.

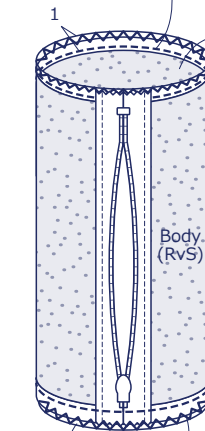

② Apply zigzag stitches on the end.

5. Attach the handle

① Make the handle.

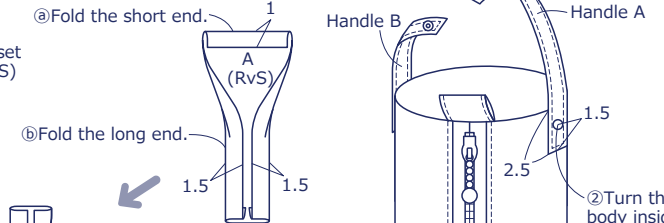

③ With the front sides facing outside, fold in half and sew.

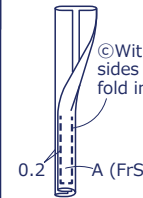

④ Attach the Plsnap.

• Repeat the same process for B (Use Plsnap ◻)

