



Box Shaped Shoulder Bag

Design & work: Satomi Takei

Size (Body): 15cm (l)
27cm (w – at opening)
5cm (gusset)

Materials

- Fabric (Panel Outer Fabric, Tab): 100cm x 25cm
- Fabric (Gusset Outer Fabric): 60cm x 10cm
(Lining Fabric): 70cm x 30cm
- Fusible Quilt Batting: 60cm x 45cm
- Two-Way Separating Plastic Zipper: 40cm long x one piece
- D Ring: 2cm wide x two pieces

Fabric shown for this sample: (Panel Outer Fabric, Tab) YGA-69000-2C
(Gusset Outer Fabric) YGA-69010-2D

Pattern and Cutting Layout

Unit: cm []: Seam Allowance Add 1cm seam unless otherwise specified.

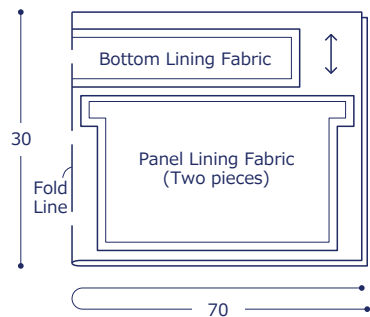
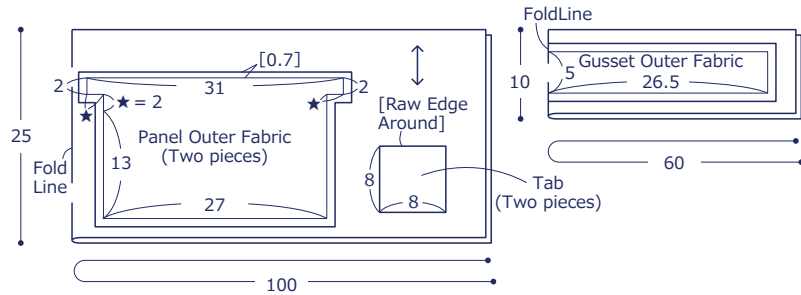

※Cut the lining fabric with the same measurement as the outer fabric.

Instructions Front Side - (FrS), Reverse Side (RvS)

1. Make the outer fabric

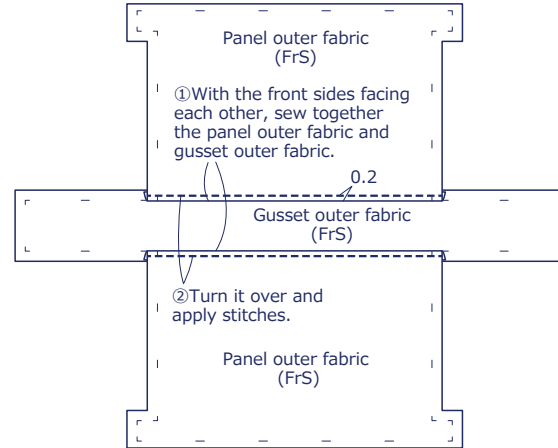

2. Make the lining fabric

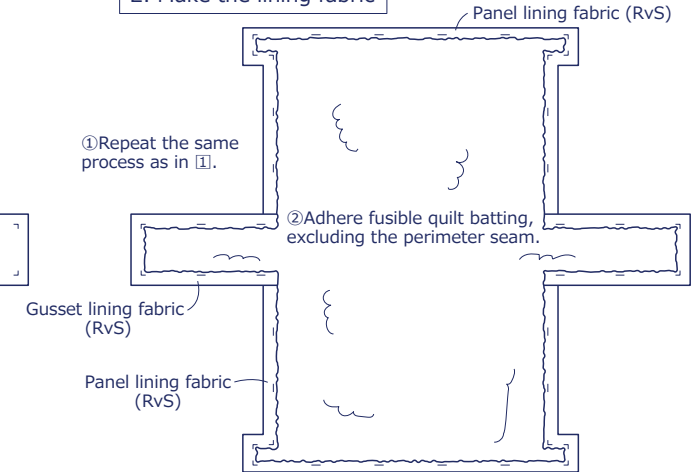

3. Attach the zipper

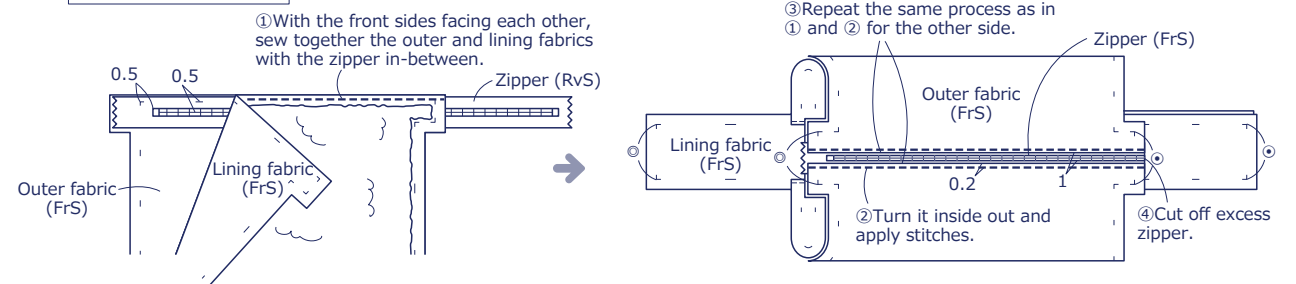

4. Make the tab

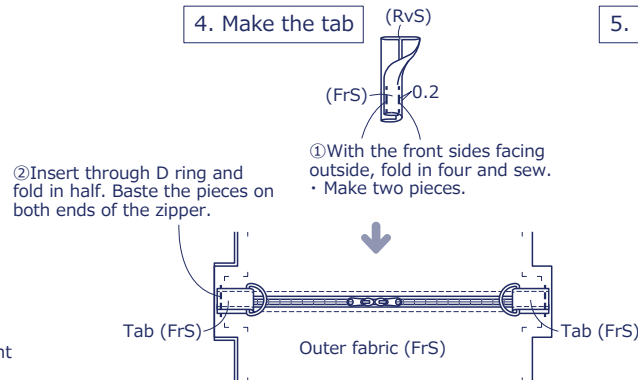

5. Finish the bag

