



Gaucha Pants

Design & Work: Yoko Kato

Size: Length about 88cm

have fun with KOKKA fabric! produced by KOKKA

kokka-fabric.com

The craft projects and works featured in kokka-fabric.com are strictly for personal use and enjoyment. Please refrain from selling handmade items using the same exact design (including the pieces made in different fabrics) featured in kokka-fabric.com.

Materials

- Fabric: 110cm wide x 1.9m
- Elastic Tape: 3cm wide – Size S: 61cm, Size M: 64cm, Size L: 69cm, Size LL: 73cm

Fabric shown for this sample: YKA-660-1A

Pattern

Unit: cm.
Draw curved line of the rise using the pattern.
(Refer to the second sheet for patterns)

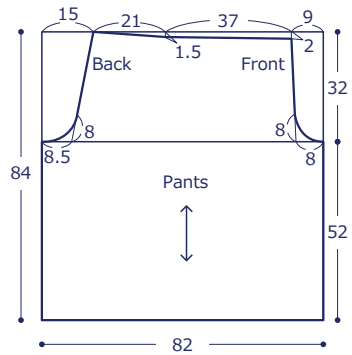

Cutting Layout

[] denotes seam allowance.
Add 1cm unless specified otherwise.

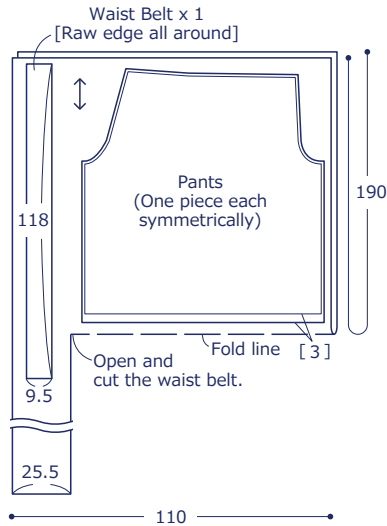

Instructions Front Side - (FrS), Reverse Side (RvS)

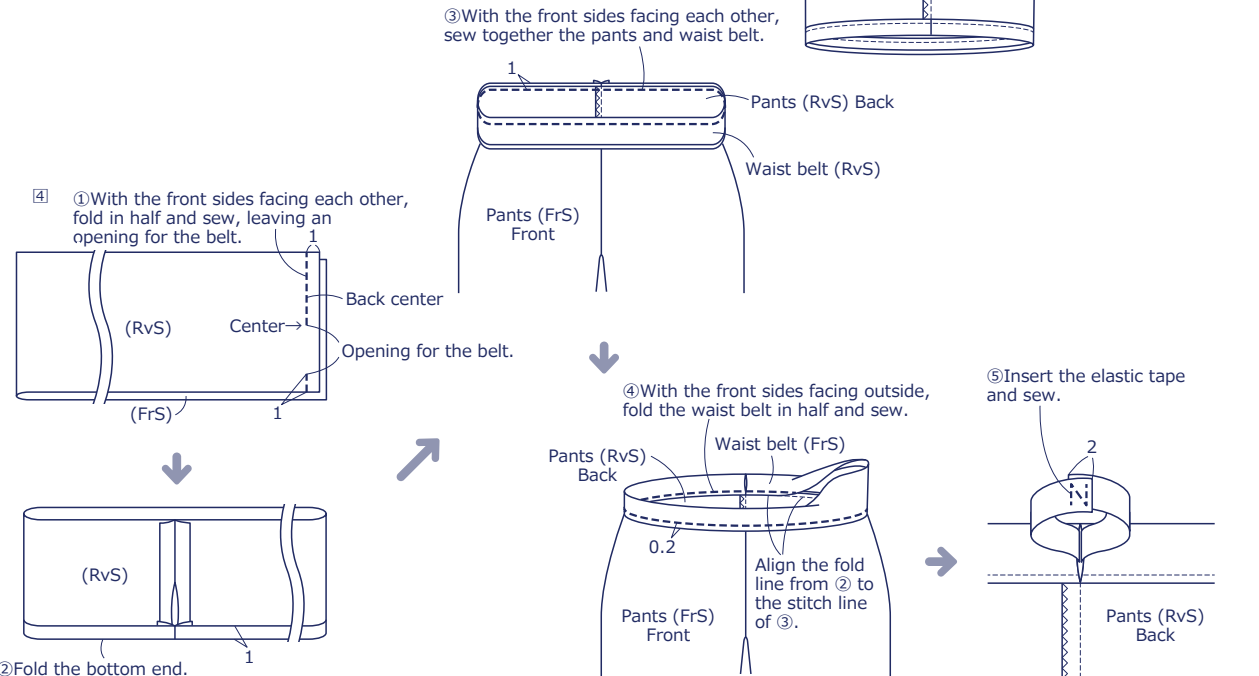
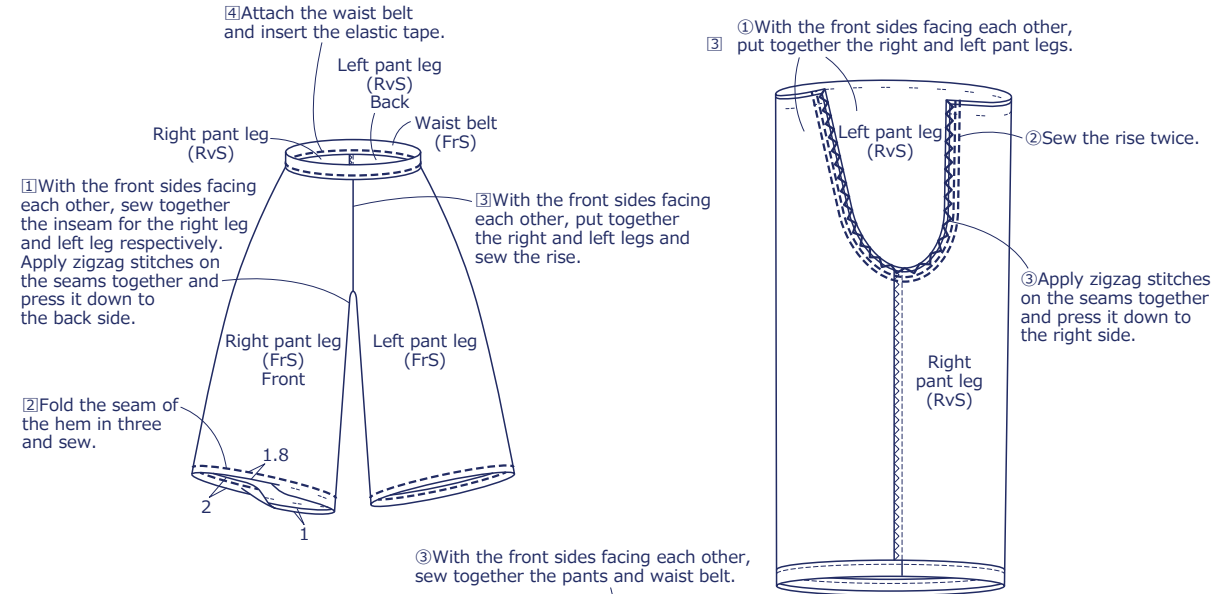

Pattern

Rise Curve

Back

Front

